

61-1004RK/61-0191RK CO₂ Detector Operator's Manual

Part Number: 71-0145RK

Revision: A

Released: 4/12/11

WARNING

Read and understand this instruction manual before operating detector. Improper use of the detector could result in bodily harm or death.

Periodic calibration and maintenance of the detector is essential for proper operation and correct readings. Please calibrate and maintain this detector regularly! Frequency of calibration depends upon the type of use you have and the sensor types. Typical calibration frequencies for most applications are between 6 and 12 months, but can be required more often or less often based on your usage.

Product Warranty

RKI Instruments, Inc. warrants gas alarm equipment sold by us to be free from defects in materials, workmanship, and performance for a period of one year from date of shipment from RKI Instruments, Inc. Any parts found defective within that period will be repaired or replaced, at our option, free of charge. This warranty does not apply to those items which by their nature are subject to deterioration or consumption in normal service, and which must be cleaned, repaired, or replaced on a routine basis. Examples of such items are:

- a) Absorbent cartridges
- b) Pump diaphragms and valves
- c) Fuses
- d) Batteries
- e) Filter elements

Warranty is voided by abuse including mechanical damage, alteration, rough handling, or repair procedures not in accordance with the operator's manual. This warranty indicates the full extent of our liability, and we are not responsible for removal or replacement costs, local repair costs, transportation costs, or contingent expenses incurred without our prior approval.

THIS WARRANTY IS EXPRESSLY IN LIEU OF ANY AND ALL OTHER WARRANTIES AND REPRESENTATIONS, EXPRESSED OR IMPLIED, AND ALL OTHER OBLIGATIONS OR LIABILITIES ON THE PART OF RKI INSTRUMENTS, INC. INCLUDING BUT NOT LIMITED TO, THE WARRANTY OF MERCHANTABILITY OR FITNESS FOR A PARTICULAR PURPOSE. IN NO EVENT SHALL RKI INSTRUMENTS, INC. BE LIABLE FOR INDIRECT, INCIDENTAL, OR CONSEQUENTIAL LOSS OR DAMAGE OF ANY KIND CONNECTED WITH THE USE OF ITS PRODUCTS OR FAILURE OF ITS PRODUCTS TO FUNCTION OR OPERATE PROPERLY.

This warranty covers instruments and parts sold to users by authorized distributors, dealers, and representatives as appointed by RKI Instruments, Inc.

We do not assume indemnification for any accident or damage caused by the operation of this gas monitor, and our warranty is limited to the replacement of parts or our complete goods.

Table of Contents

Overview	1
Specifications	1
Description	2
IR CO ₂ Detector	2
Junction Box	3
Installation	4
Mounting the CO ₂ Detector	4
Wiring the CO ₂ Detector to a Controller	5
Startup	7
Introducing Incoming Power	7
Setting the Zero Signal	7
Maintenance	8
Preventive Maintenance	8
Troubleshooting	9
Replacing the CO ₂ Detector	10
Calibration Frequency	10
Calibration	11
Preparing for Calibration	11
Setting the Zero Reading	11
Setting the Response Reading	11
Returning to Normal Operation	12
Parts List	13

Overview

This manual describes the 61-1004RK CO₂ (carbon dioxide) detector. This manual also describes how to install, start up, maintain, and calibrate the detector when used with a gas monitoring controller. A parts list at the end of this manual lists replacement parts and accessories for the CO₂ detector.

The 61-1004RK CO₂ detector includes the 61-0191RK detector and a junction box. This manual may also be used for the 61-0191RK CO₂ detector which does not include a junction box and is normally mounted in one of a controller's conduit hubs and factory wired to the controller. If you are using a 61-0191RK CO₂ detector, disregard all references to the junction box and junction box terminal block.

Specifications

Table 1 lists specifications for the CO₂ detector.

Table 1: 61-1004RK Specifications

Detection Range	<u>With Junction Box</u> 61-1004RK-02: 0 - 5,000 ppm CO ₂ 61-1004RK-03: 0 - 5% Volume CO ₂ 61-1004RK-05: 0 - 50% Volume CO ₂ 61-1004RK-10: 0 - 100% Volume CO ₂ <u>Without Junction Box</u> 61-0191RK-02: 0 - 5,000 ppm CO ₂ 61-0191RK-03: 0 - 5% Volume CO ₂ 61-0191RK-05: 0 - 50% Volume CO ₂ 61-0191RK-10: 0 - 100% Volume CO ₂
Area Classification	Explosionproof for Class I, Groups B, C, and D
Sampling Method	Diffusion
Response Time	90% in 45 seconds
Accuracy	± 5% of reading or ± 2% of full scale (whichever is greater)

WARNING: *When using the 61-1004RK, you must follow the instructions and warnings in this manual to assure proper and safe operation of the 61-1004RK and to minimize the risk of personal injury. Be sure to maintain and periodically calibrate the 61-1004RK as described in this manual.*

Description

The 61-1004RK CO₂ detector has four versions, the 61-1004RK-02 which has a detection range of 0 - 5,000 ppm, the 61-1004RK-03 which has a detection range of 0 - 5% volume, the 61-1004RK-05 which has a detection range of 0 - 50% volume, and the 61-1004RK-10 which has a detection range of 0 - 100% volume. The detector is an infrared type of detector. This section describes the components of the 61-1004RK and 61-0191RK detectors. The 61-1004RK includes the 61-0191RK detector and a junction box. A four point terminal strip is provided inside the junction box for detector connections. The 61-0191RK does not include a junction box. Figure 1 below shows the components of the 61-1004RK.

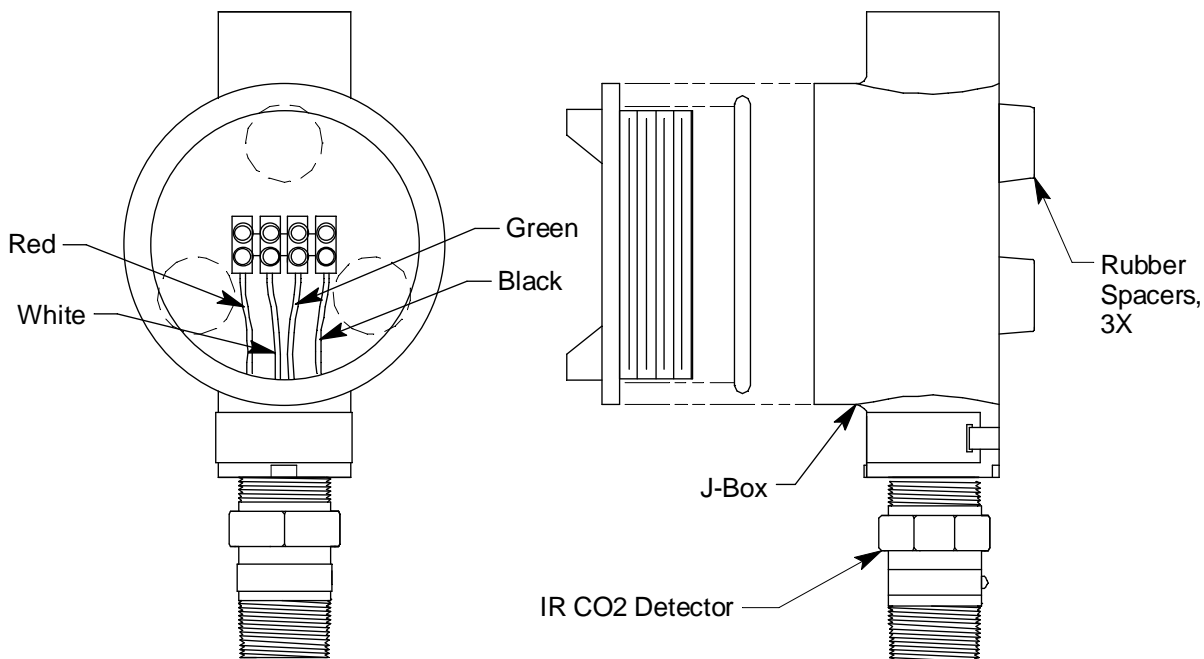

Figure 1: 61-1004RK Component Location

61-0191RK Infrared CO₂ Detector

The infrared CO₂ detector is made up of a miniature infrared CO₂ detector housed and encapsulated in a pipe nipple. The pipe nipple has 3/4 inch NPT threads on each end and a 1-1/4 inch hex that allows removal or installation of the detector with a wrench. A porous flame arrestor coated with a hydrophobic film that repels liquids is on one end of the detector and allows sample gas to enter the detector. Four color coded leads, red, white, green, and black, extend from the other end of the detector. The leads allow you to connect the detector to the terminal block in the junction box.

To distinguish the different ranges of CO₂ detectors from one another, a short length of shrink tubing is applied to the wiring where it comes out of the nipple. The following table indicates the color of the shrink tubing and the color of the wire to which it is applied.

Table 2: CO₂ Detector Color Designations

Detector	Color Designations
0 - 5,000 ppm	black shrink tubing on white wire
0 - 5% volume	green shrink tubing on white wire
0 - 50% volume	green shrink tubing on red wire
0 - 100% volume	red shrink tubing on green wire

The output of the CO₂ detector mimics the output of RKI's standard catalytic LEL detectors. For this reason, the CO₂ detector's wire colors are the same as RKI's catalytic LEL detectors, black, white, green, and red. When the CO₂ detector is wired to an RKI controller, it is wired the same way an LEL detector is wired, to the LEL detector terminals. See "Wiring the CO₂ Detector to a Controller" on page 5 for wiring connections.

Junction Box

The junction box allows you to install the detector at a mounting site that is remote from a controller and it protects the detector wiring connections. Two 3/4" NPT conduit hubs allow you to mount the detector to the junction box and connect the wiring from the detector to a controller. The terminal block within the junction box facilitates the wiring to the detector. A cover on the front of the junction box allows access to the interior of the junction box. Three spacers installed on the back of the junction box control the distance of the junction box from a mounting surface and ensure that there is enough room to install a calibration cup on the detector during calibration.

Installation

This section describes procedures to mount the CO₂ detector in the monitoring environment and wire it to a controller. If you purchased a 61-0191RK detector that is factory installed in and factory wired to a controller, detector installation is not necessary.

Mounting the CO₂ Detector

1. Select a mounting site that is representative of the monitoring environment. Consider the following when you select the mounting site.
 - Select a site where the detector is not likely to be bumped or disturbed. Make sure there is sufficient room to perform start-up, maintenance, and calibration procedures.
 - Select a site where the target gas is likely to be found first.
 - Select a site that minimizes the possibility of someone breathing on the detector. The exhaled CO₂ may cause an alarm.

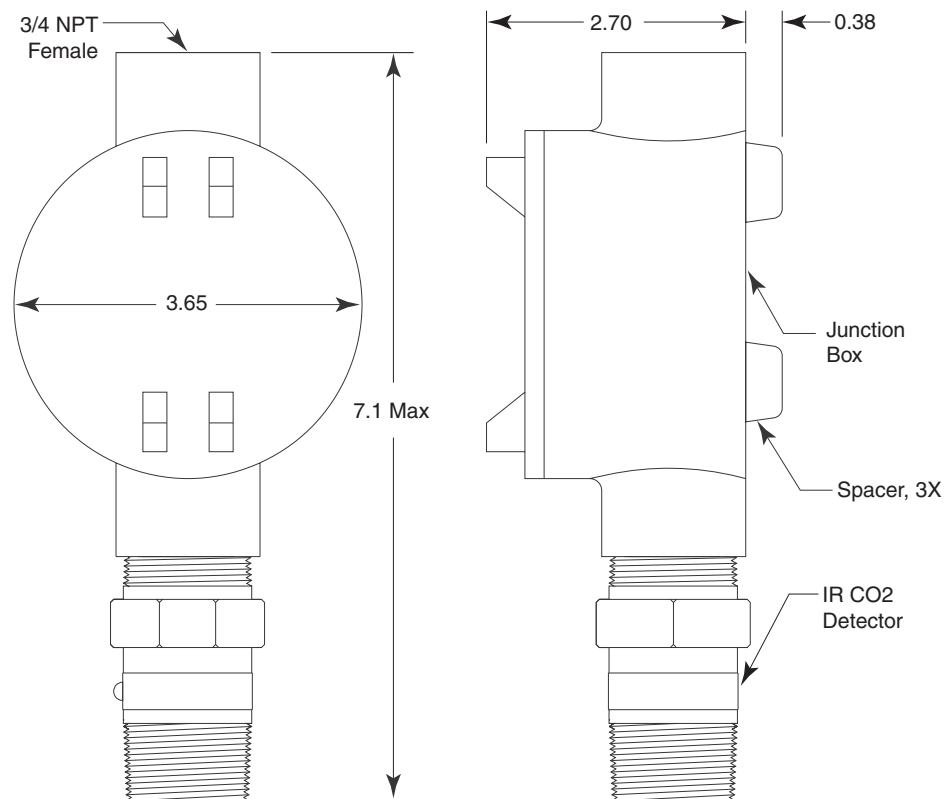

Figure 2: Mounting the CO₂ Detector

2. At the mounting site you select, hang or mount the junction box with the detector facing down (see Figure 2).

Wiring the CO₂ Detector to a Controller

WARNING: *Always verify that the power to the controller is off before you make wiring connections.*

As mentioned in “Description” on page 2, the IR CO₂ detector wires to an RKI controller the same way as an RKI LEL detector, to the LEL detector terminals. See Figure 3 below for the wiring connections.

1. Turn off the controller.
2. Turn off or unplug power to the controller.
3. If the detector is mounted remotely from a controller using the junction box, proceed to step 4.

If the detector is mounted directly to a controller, it is normally factory wired. Confirm that the detector’s wires are connected to the appropriate controller detector terminals and skip to “Start Up” on page 7. See Figure 3, the controller operator’s manual, and the controller’s detector head specification sheet for the 61-0191RK detector for the wiring connections.

4. Remove the cover from the junction box.
5. Guide a four-conductor, shielded cable or four wires in conduit through the top conduit hub of the junction box. Use appropriate conduit fittings and construction technique for the environmental rating of the junction box. The junction box is rated NEMA 4X.
6. Connect the wires to the terminals opposite the detector leads.

CAUTION: *If using shielded cable. Leave the shield drain wire insulated and disconnected at the 61-1004RK. You will connect the opposite end of the cable’s drain wire at the controller.*

7. Secure the junction box cover to the junction box.
8. Route the cable or wires in conduit leading from the detector through one of the conduit hubs at the controller. Use appropriate conduit fittings and construction technique for the environmental rating of the controller. RKI controllers are typically rated NEMA 4X.

CAUTION: *Do not route power and detector wiring through the same conduit hub. The power cable may disrupt the transmission of the detector signal to the controller.*

9. Connect the wires to the applicable controller terminal strip. See the controller operator’s manual and the controller’s detector head specification sheet for the 61-1004RK detector.

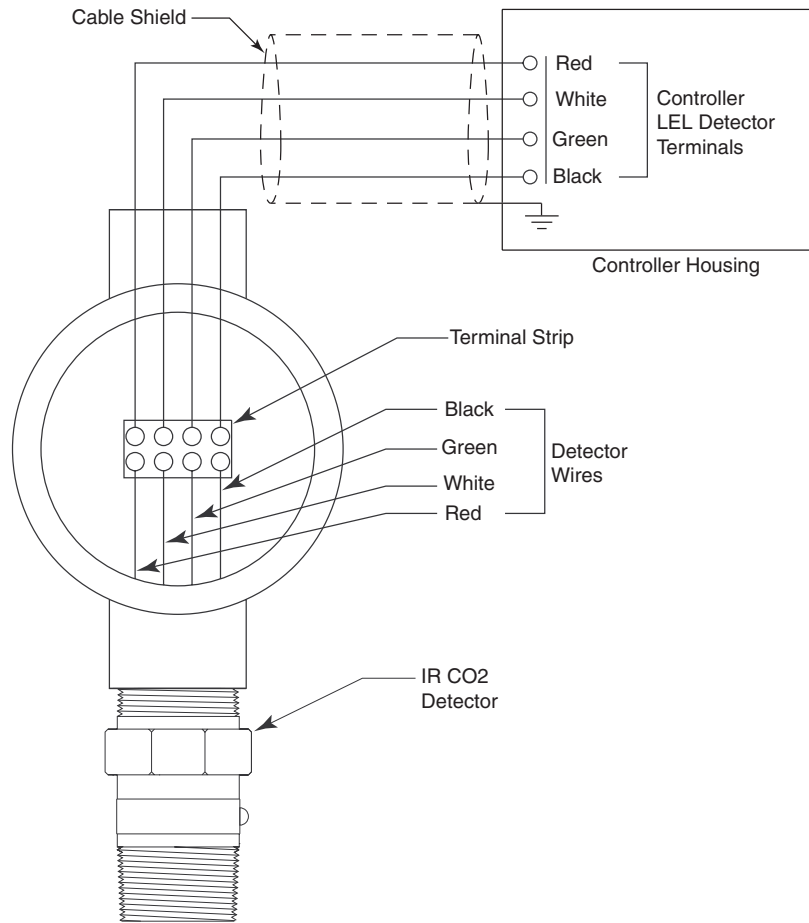

Figure 3: Wiring the CO₂ Detector to a Controller

10. If using shielded cable, connect the cable's drain wire to an available chassis ground at the controller. RKI controllers typically have a ground stud that is a convenient grounding location.

Start Up

This section describes procedures to start up the CO₂ detector and place the detector into normal operation.

Introducing Incoming Power

1. Complete the installation procedures described earlier in this manual.
2. Verify that the power wiring to the controller is correct and secure. Refer to the controller operator's manual.
3. Turn on or plug in power to the controller, then turn on the controller.
4. Verify that the controller is on and operating properly. Refer to the controller operator's manual.

CAUTION: *Allow the detector to warm up for 5 minutes before you continue with the next section, "Setting the Zero Signal".*

Setting the Zero Signal

Since there is a background of CO₂ in air of typically 200 - 400 ppm, it is necessary to use a calibration kit with a CO₂ free gas to set the zero signal of a low range CO₂ detector. Fresh air can be used to zero the detector if a 0-50 %volume or 0-100 %volume detector is being used.

The procedure below describes applying 100% nitrogen to the detector using a calibration kit that includes a calibration cup, a calibration cylinder of 100% nitrogen, sample tubing, and a 0.5 LPM (liters per minute) fixed flow regulator with an on/off knob.

1. Screw the calibration cup onto the bottom of the CO₂ detector.
2. Screw the regulator into the 100% nitrogen calibration cylinder.
3. Use the sample tubing to connect the regulator to the calibration cup.
4. Turn the regulator's on/off knob counterclockwise to open it. Gas will begin to flow.
5. Allow the gas to flow for one minute.
6. Verify a reading of 0% CO₂ or 0 ppm CO₂ depending on the detector you are calibrating at the controller.

If the display reading is 0, the CO₂ detector is in normal operation and start up is complete. Proceed to step 7 to disassemble the calibration kit.

If the display reading is not 0, turn the regulator's on/off knob clockwise to close it, then proceed to "Setting the Zero Reading" on page 11 to set the zero reading.

7. Turn the regulator's on/off knob clockwise to close it.
8. Unscrew the cylinder from the regulator and remove the sample tubing from the regulator.
9. Remove the calibration cup from the detector. You may leave the sample tubing connected to the calibration cup for convenience.
10. Store the components of the calibration kit in a safe and convenient place.

Maintenance

This section describes maintenance procedures. It includes preventive maintenance, troubleshooting, and component replacement procedures.

Preventive Maintenance

This section describes a preventive maintenance schedule to ensure the optimum performance of the CO₂ detector. It includes daily, monthly, and biannual procedures.

Daily

Verify a display reading at the controller of the background concentration of CO₂. Typical background concentrations of CO₂ vary from about 200 to 400 ppm depending on location. The 0-5,000 ppm and 0-5 %volume detectors will display a reading in a fresh air environment because they have low ranges. The 0-50 %volume and 0-100% volume detectors will not display a reading in fresh air because their ranges are too large. Investigate significant changes in the display reading.

Monthly

This procedure describes a test to verify that the CO₂ detector responds properly to the target gas.

WARNING: *The controller is not an active gas monitoring device during the response test procedure.*

NOTE: Performing a response test on the CO₂ detector may cause alarms. Be sure to put the controller into its calibration program or disable external alarms before performing this test.

The procedure below describes applying CO₂ to the detector using a calibration kit that includes a calibration cup, a CO₂ calibration gas cylinder, sample tubing, and a 0.5 LPM (liters per minute) fixed flow regulator with an on/off knob.

1. Place the controller into its calibration program or disable external alarms.
2. Verify that the controller display reading for the channel you are testing is consistent with typical background levels of CO₂.

If the reading is not consistent with typical background levels of CO₂, set the zero reading then continue this procedure. See "Setting the Zero Reading" on page 11 to set the zero reading.

3. Screw the calibration cup onto the detector.
4. Use the sample tubing to connect the regulator to the calibration cup.
5. Screw the regulator into the calibration cylinder.
6. Turn the on/off knob on the regulator counterclockwise to open the regulator.
7. Apply gas to the detector for one minute.
8. Verify that the reading is within $\pm 20\%$ of the gas concentration.

NOTE: If the reading is not within $\pm 20\%$ of the gas concentration, calibrate the detector as described in “Calibration” on page 11.

9. Turn the on/off knob clockwise to close the regulator.
10. Unscrew the regulator from the calibration cylinder and remove the sample tubing from the regulator.
11. Unscrew the calibration cup from the detector. You may leave the sample tubing connected to the calibration cup for convenience.
12. When the display reading falls below the alarm setpoints, return the controller to normal operation or enable external alarms.
13. Store the components of the calibration kit in a safe place.

Biannually

Calibrate the CO₂ detector every six months as described in “Calibration” on page 11.

Troubleshooting

The troubleshooting guide describes symptoms, probable causes, and recommended action for problems you may encounter with the CO₂ detector.

NOTE: This troubleshooting guide describes detector problems only. See the controller operator’s manual for problems you may encounter with the controller.

Table 3: Troubleshooting the CO₂ Detector

Condition	Symptom(s)	Probable Causes	Recommended Action
Fail Condition	<ul style="list-style-type: none"> • Controller indicates a fail condition. 	<ul style="list-style-type: none"> • The detector wiring is disconnected or misconnected. • The detector zero signal is low enough to cause a fail condition. • The detector is malfunctioning. 	<ol style="list-style-type: none"> 1. Verify that the detector wiring is correct and secure. 2. Calibrate the detector. 3. If the fail condition continues, replace the detector. 4. If the fail condition continues, contact RKI for further instruction.
Slow or No Response/ Difficult or Unable to Calibrate	<ul style="list-style-type: none"> • Detector responds slowly or does not respond to response test. • Unable to accurately set the zero or response reading during calibration. • Detector requires frequent calibration. <p><i>Note: Under “normal” circumstances, the detector requires calibration once every six months. Some applications may require a more frequent calibration schedule.</i></p>	<ul style="list-style-type: none"> • The calibration cylinder is low, out-dated, or defective. • The regulator flow rate is not 0.5 LPM. • The detector is malfunctioning. 	<ol style="list-style-type: none"> 1. Verify that the calibration cylinder contains an adequate supply of a fresh test sample. 2. Confirm that the regulator being used is a 0.5 LPM regulator. 3. If the calibration/response difficulties continue, replace the detector. 4. If the calibration/response difficulties continue, contact RKI for further instruction.

Replacing the CO₂ Detector

1. Turn off the controller.
2. Turn off power to the controller.
3. If the detector is installed directly on a controller, open the controller door.
If the detector is installed remotely from a controller in a junction box, remove the junction box cover.
4. If the detector is installed directly on a controller, disconnect the detector leads from the detector terminal strip in the controller. Note the position of the color-coded leads as you remove them.
If the detector is installed remotely from a controller in a junction box, disconnect the detector leads from the terminal block in the junction box. Note the position of the color-coded leads as you remove them.
5. Unscrew the detector from the controller conduit hub or junction box conduit hub.
6. Guide the detector leads of the replacement detector through the controller conduit hub or junction box conduit hub, then screw the mounting threads of the detector into the hub. If necessary for environmental conditions, apply thread sealant or teflon tape to the hub and/or detector threads to seal them.
7. If the detector is installed directly on a controller, connect the detector leads to the appropriate detector terminal strip terminals. See Figure 3 on page 6 for wiring to a generic controller. See the controller operator's manual and the controller's detector head specification sheet for the 61-0191RK detector for wiring specific to your controller.
If the detector is installed remotely from a controller in a junction box, connect the detector leads to the terminal block the same way the old detector was wired (see Figure 3 on page 6). See the controller operator's manual and the controller's detector head specification sheet for the 61-1004RK detector to verify the connections to the controller are correct.
8. If the detector is installed remotely from a controller in a junction box, reinstall the junction box cover.
9. Turn on power to the controller.
10. Turn on the controller.
11. Calibrate the replacement detector as described in "Calibration" on page 11.

Calibration Frequency

Although there is no particular calibration frequency that is correct for all applications, a calibration frequency of every 6 months is adequate for most infrared CO₂ detector applications. Unless experience in a particular application dictates otherwise, RKI Instruments, Inc. recommends a calibration frequency of every 6 months for the infrared CO₂ detector.

If an application is not very demanding, for example detection in a clean, temperature controlled environment where CO₂ is not normally present, and calibration adjustments are minimal at calibration, then a calibration frequency of every 9 to 12 months is adequate.

If an application is very demanding, for example if the environment is not well controlled,

then more frequent calibration than every 6 months may be necessary.

Calibration

This section describes how to calibrate the CO₂ detector. It includes procedures to prepare for calibration, set the zero reading, set the response reading, and return to normal operation.

WARNING: *The controller is not an active gas monitoring device during the calibration procedure.*

The following procedure assumes the use of a calibration kit which includes a 100% nitrogen calibration gas cylinder for setting the zero reading, a CO₂ calibration gas cylinder for setting the response reading, a 0.5 LPM fixed flow regulator with an on/off knob, a calibration cup for the detector, and a short piece of sample tubing to connect the regulator to the calibration cup.

Preparing For Calibration

1. Screw the calibration cup onto the detector.
2. Use the sample tubing to connect the regulator to the calibration cup.
3. Place the controller into its calibration program or disable external alarms.

NOTE: Calibrating the CO₂ detector may cause alarms. Be sure to put the controller into its calibration program or disable external alarms before continuing.

Setting the Zero Reading

Since there is a background of CO₂ in air of typically 200 - 400 ppm, it is necessary to use a calibration kit with a CO₂ free gas to set the zero signal of a low range CO₂ detector. Fresh air can be used to zero the detector if a 0-50 %volume or 0-100 %volume detector is being used.

1. Follow the directions in the controller's operator's manual for setting the zero reading (sometimes called the fresh air reading).
2. When the directions call for exposing the detector to zeroing gas, screw the regulator into the cylinder, turn the on/off knob counterclockwise to open the regulator, and allow the gas to flow to the detector for 1 minute.
3. Turn the regulator's on/off knob clockwise to close the regulator.
4. Set the zero reading according to the controller's operator's manual.
5. Unscrew the 100% nitrogen cylinder from the regulator.

Setting the Response Reading

1. Follow the directions in the controller's operator's manual for setting the response reading (span).
2. When the directions call for exposing the detector to calibration gas, screw the CO₂ cylinder onto the regulator, turn the on/off knob counterclockwise to open the regulator, and allow the gas to flow to the detector for 1 minute.
3. Turn the regulator's on/off knob clockwise to close the regulator.

4. Set the response reading according to the controller's operator's manual.
5. Unscrew the CO₂ cylinder from the regulator.

Returning to Normal Operation

1. Remove the sample tubing from the regulator.
2. Remove the calibration cup from the detector. Leave the sample tubing connected to the calibration cup for convenience.
3. Allow the reading at the controller to decrease below the alarm points before returning the controller to normal operation or enabling external alarms.

NOTE: If you do not allow the gas reading to decrease below the alarm points, then unwanted alarms may occur.

4. Verify that the controller display reading decreases and stabilizes at a typical background CO₂ level. The 0-5,000 ppm and 0-5 %volume detectors will display a reading in a fresh air environment because they have low ranges. The 0-50 %volume and 0-100 %volume detectors will not display a reading in fresh air because their ranges are too large.
5. Store the components of the calibration kit in a safe and convenient place.

Parts List

Table 3 lists replacement parts and accessories for the 61-1004RK and 61-0191RK CO₂ detectors.

Table 4: Parts List

Part Number	Description
18-0400RK-01	Junction box with spacers
61-0191RK-02	Infrared CO ₂ detector, 0 - 5,000 ppm
61-0191RK-03	Infrared CO ₂ detector, 0 - 5% Volume
61-0191RK-05	Infrared CO ₂ detector, 0 - 50% Volume
61-0191RK-10	Infrared CO ₂ detector, 0 - 100% Volume
71-0145RK	<i>61-1004RK/61-0191RK CO₂ Detector Operator's Manual (this document)</i>
81-0070RK-01	Steel calibration cylinder, 2,000 ppm CO ₂ in nitrogen, 34 liter
81-0072RK-01	Steel calibration cylinder, 2.5% CO ₂ in nitrogen, 34 liter
81-0073RK-01	Steel calibration cylinder, 15% CO ₂ in nitrogen, 34-liter
81-0078RK-01	100% nitrogen calibration cylinder (34 liter)
81-1050RK	Regulator, 0.5 liter/minute, with gauge and knob, for 17- and 34-liter calibration cylinders
81-1103RK	Calibration cup
81-F403RK-LV	Calibration kit, for 3/4" NPT detector, 2.5% CO ₂ , 34 liter
81-F404RK-LV	Calibration kit, for 3/4" NPT detector, 2,000 ppm CO ₂ , 34 liter