

Instruction Manual

HI 8931 • HI 8936 Series

Conductivity Process Controllers and Transmitters

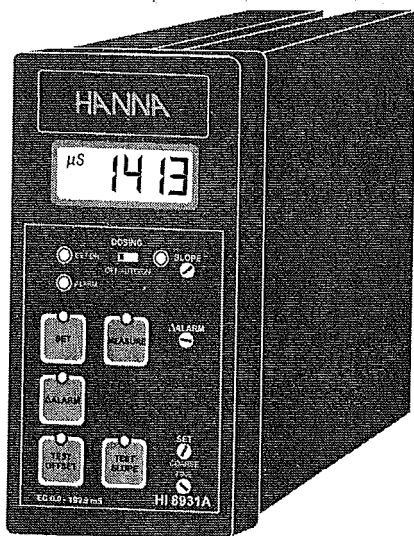

w w w . h a n n a i n s t . c o m

Dear Customer,

Thank you for choosing a HANNA instruments® product.

Please read this instruction manual carefully before using the instrument.

This manual will provide you with all the necessary information for correct use of the instruments, as well as a precise idea of their versatility in a wide range of applications.

If you need additional technical information, do not hesitate to e-mail us at tech@hannainst.com

These instruments are in compliance with the CE directives.

TABLE OF CONTENTS

Preliminary Examination	3
General Description	3
Functional Description HI 8931	5
Functional Description HI 8936	8
Conductivity Probes	11
Specifications HI 8931	13
Specifications HI 8936	14
Connections	15
Operational Guide	21
Calibration Procedure of HI 8931 & HI 8936 with HI 7635	28
Calibration Procedure of HI 8931 & HI 8936 with HI 7638	32
Calibration Procedure of HI 8931 with HI 7638	36
Conductivity Versus Temperature Chart	38
Diagnostic Tests	39
Installation Examples	41
Probe Maintenance and Cleaning	43
Accessories	44
Warranty	46

PRELIMINARY EXAMINATION

Remove the instrument from the packing material and examine it carefully to make sure that no damage has occurred during shipping. If there is any noticeable damage, notify your dealer.

Each model is supplied complete with:

- Mounting brackets (not for HI 8936 series)
- Transparent splash-proof cover (not for HI 8936 series)
- Instruction manual

Note: Save all packing materials until you are sure that the instrument functions correctly. All defective items must be returned in the original packing materials together with the supplied accessories.

GENERAL DESCRIPTION

HI 8931 is a panel-mounted conductivity controller designed for simplicity of use in a wide range of industrial process applications.

The instruments are designed with a standard DIN panel mount with membrane keypads and large LCD with backlight on the front, and provide a series of auto-diagnostic functions.

Probes, power supply, contacts and recorders are connected on the rear panel through screw terminals.

Using HI 8931 in conjunction with a 4-20 mA output transmitter (HI 8936 or HI 8936L series) will assure you of a strong, interference-free signal at distances up to 300 meters (1000').

For in-line applications use the HI 7635 probe, while for tanks the HI 7638 with external threads is recommended. These probes are provided with built-in NTC sensor for temperature compensated conductivity measurements. The probe cable length is 3 meters (10').

HI 8931 also features a direct connection up to 20 m (67'), without intermediate amplifiers, to the conductivity probe HI 7638 with DIN connector and automatic temperature compensation.

Four models with different measurement ranges are available to suit any application needs:

- HI 8931A / HI 8936A / HI 8936AL from 0.0 to 199.9 mS/cm
- HI 8931B / HI 8936B / HI 8936BL from 0.00 to 19.99 mS/cm
- HI 8931C / HI 8936C / HI 8936CL from 0 to 1999 μ S/cm
- HI 8931D / HI 8936D / HI 8936DL from 0.0 to 199.9 μ S/cm

Other features include (for HI 8931): recorder output in 0-20 mA or 4-20 mA configuration; LED indicators which identify whether the controller is in operation mode or selection mode; overtime control function.

Each instrument of the HI 8931 series, is supplied with a plastic front cover and two mounting brackets. Power cables are not included.

Note: In order to avoid malfunctions and erroneous readings:

- do never connect more than one electrode type (DIN or input transmitter) to the instrument
- do never use both 0-20 mA and 4-20 mA recorder outputs at the same time

FUNCTIONAL DESCRIPTION HI 8931

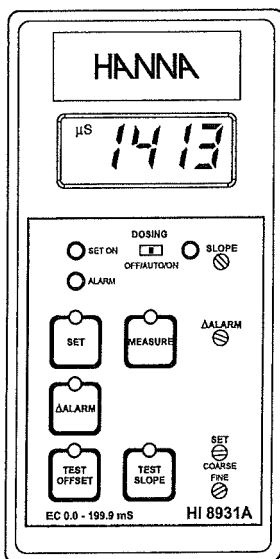

KEYPAD

MEASURE

To read measurements and enable diagnostic tests

ΔALARM

To display and set tolerance of the alarm

SET

To display and set the working dosing point

TEST SLOPE

Diagnostic function

TEST OFFSET

Diagnostic function

When a key is pressed, the corresponding LED lights up to indicate that the function is active.

TRIMMERS

SLOPE

For slope calibration

ΔALARM

To set the alarm tolerance

SET COARSE

To coarsely adjust the set point

SET FINE

To finely adjust the set point

LEDS

SET ON

To indicate that the dosage is active

ΔALARM

To indicate an alarm condition

DOSAGE MODE SWITCH To indicate that the continuous ON or OFF mode is selected from dosing switch

SWITCH

OFF/AUTO/ON

To select the dosing mode:

- **OFF** - dosing is disabled
- **AUTO** - automatic dosage, depending on setpoint value and dosing selection
- **ON** - dosing always active

REAR PANEL OF HI 8931 SERIES

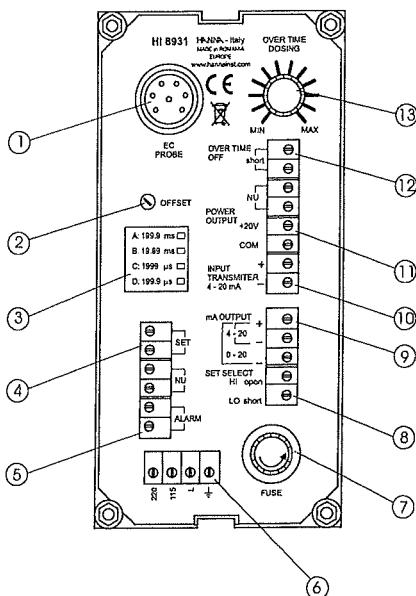

1. DIN connector for EC probe
2. Trimmer for offset calibration
3. Label with marked A, B, C or D instrument type
4. SET terminals for connection to a dosing pump
5. ALARM terminals for connection to an external alarm device
6. Power supply terminals
7. Fuse holder
8. SET SELECT terminals for reverse control operation
9. mA OUTPUT terminals for connection to a recorder
10. mA INPUT terminals from a conductivity transmitter
11. POWER OUTPUT terminals (+20 V and COM) for connection to a conductivity transmitter (HI 8936)
12. Disable overtime dosing connection
13. Overtime dosing set knob (about 5 to 60 min)



Unplug the instrument from power supply before replacing the fuse.
 Only one of DIN or INPUT TRANSMITTER can be used at a moment.
 Leave unconnected the other connection.
 Only one of recorder output connections (0-20 mA or 4-20 mA) can be used at a moment. Leave unconnected the unused terminal.

MECHANICAL DIMENSIONS
OF HI 8931

Front view of the panel-mounted unit

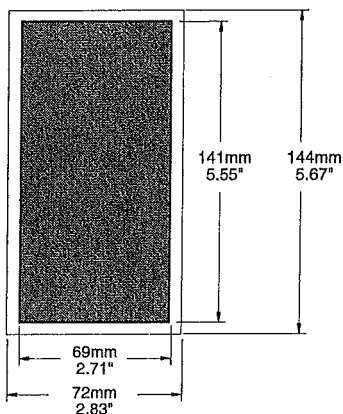

These dimensions show the cutout size for the installation.

Side view of the panel-mounted unit

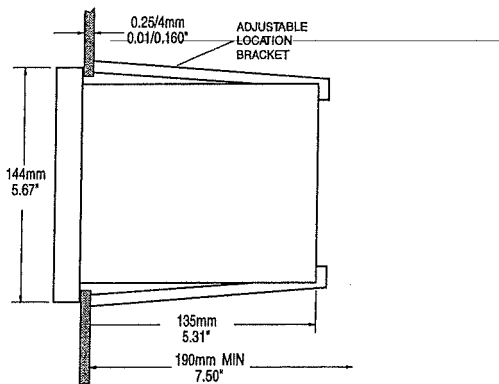

Adjustable location brackets (supplied with the meter) allow the indicator to slide into the cutout and will hold the unit securely in place. 190 mm (7.50") is the minimum amount of room required to install the indicator with the cables connected.

FUNCTIONAL DESCRIPTION HI 8936

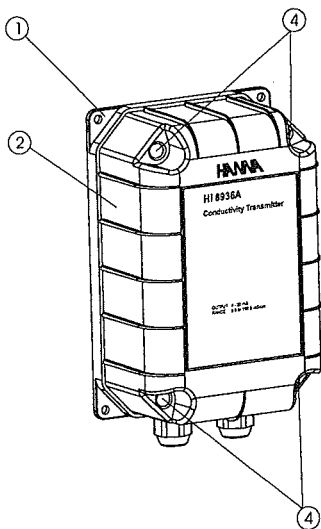

HI 8936A
HI 8936B
HI 8936C
HI 8936D

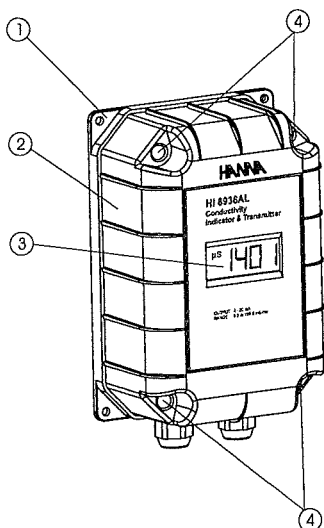

HI 8936AL
HI 8936BL
HI 8936CL
HI 8936DL

1. Back cover
2. Top cover
3. Liquid Crystal Display
4. Screws for fastening the top cover

SIDE VIEW OF HI 8936 SERIES

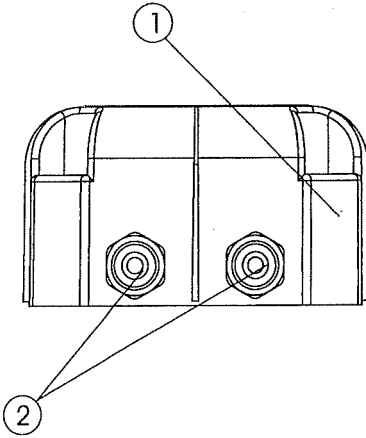

1. Top cover
2. Cable glands for wiring

MECHANICAL DIMENSIONS OF
HI 8936A, HI 8936B, HI 8936C, HI 8936D

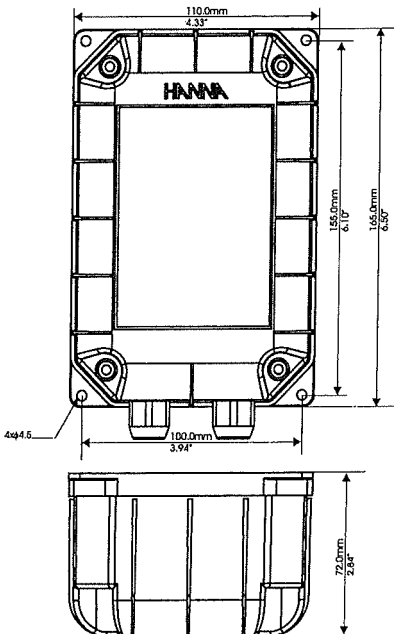

***MECHANICAL DIMENSIONS OF
HI 8936AL, HI 8936BL, HI 8936CL, HI 8936DL***

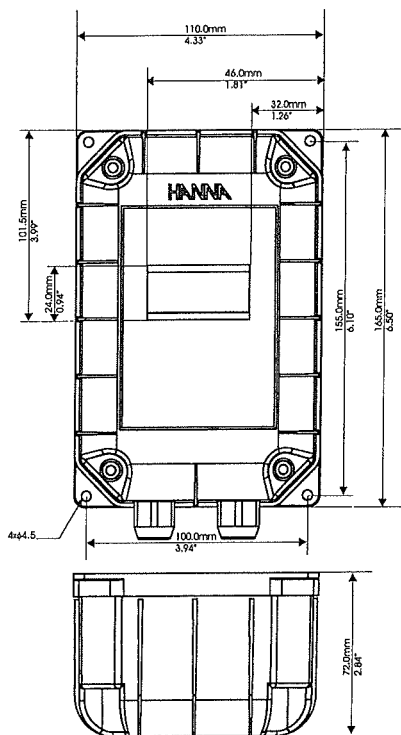

CONDUCTIVITY PROBES

HI 7635 In-line Conductivity Probe

HI7635 is a one piece, molded conductivity probe with pipe threads (1" NPT) at both ends.

This allows the probe to attach to an in-line system, and to be used in conjunction with the HI 8936 conductivity transmitter.

The HI 7635 uses a 4-ring potentiometric measuring method. This method is highly accurate and requires very little maintenance.

The construction of the housing is rugged, fiber-reinforced polypropylene.

The maximum working pressure of this unit is 5 bar (72.5 psi).

Do not use in systems where the temperature exceeds 80°C (176°F).

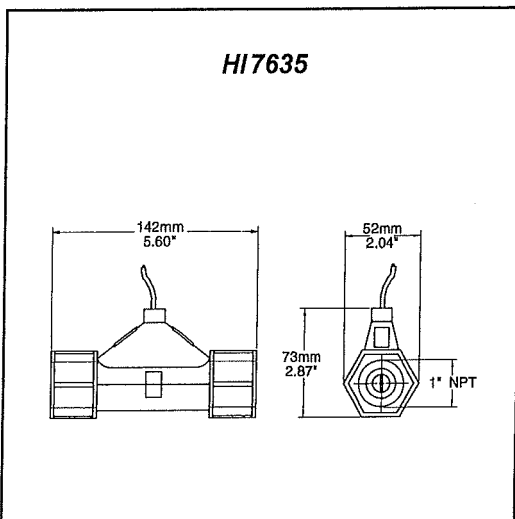

HI7638 Tank Conductivity Probe

HI 7638 conductivity probe combines the proven 4-ring potentiometric method of measuring conductivity with the platinum sensor and stainless steel external thread.

This method incorporates a series of four platinum rings into the probe shaft and is highly accurate requiring very little maintenance.

The removable plastic cover resists the harmful effect of most chemicals and can be unscrewed for quick and simple maintenance.

This probe can withstand temperatures of up to 120°C (248°F) and pressure of up to 5 bar (72.5 psi).

This probe is supplied complete with a 7-pin DIN connector.

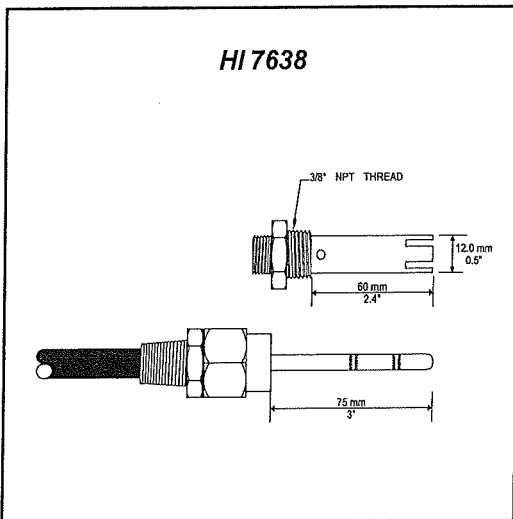

SPECIFICATIONS HI 8931

Range	
HI 8931A	0.0 to 199.9 mS/cm
HI 8931B	0.00 to 19.99 mS/cm
HI 8931C	0 to 1999 μ S/cm
HI 8931D	0.0 to 199.9 μ S/cm
Resolution	
HI 8931A	0.1 mS/cm
HI 8931B	0.01 mS/cm
HI 8931C	1 μ S/cm
HI 8931D	0.1 μ S/cm
Accuracy (@20°C/68°F)	\pm 2% of Full Scale excluding probe error
Inputs	DIN (probe) 4-20 mA (input transmitter)
Conductivity Probe	HI 7635 for in-line applications or HI 7638 for tank (not included)
Calibration	Manual, 2 point, through offset and slope trimmers
Temp. Compensation	Automatic, 0 to 60°C with $\beta=2\%/^{\circ}\text{C}$ See also transmitter HI 8936
Recorder Output	0 to 20 mA or 4 to 20 mA (isolated)
Setpoint Relay and Alarm Relay	1, Isolated, 2A, Max. 240V, resistive load, 1,000,000 strokes
Setpoint Range	
HI 8931A	0.0 to 199.9 mS/cm
HI 8931B	0.00 to 19.99 mS/cm
HI 8931C	0 to 1999 μ S/cm
HI 8931D	0.0 to 199.9 μ S/cm
Alarm Range	
HI 8931A	0.0 mS and 100.0 mS
HI 8931B	0.00 mS and 10.00 mS
HI 8931C	0 μ S and 1000 μ S
HI 8931D	0.0 μ S and 100.0 μ S
Dosing Control	OFF/AUTO/ON with selection switch
Over Dosing Control	Adjustable, from 5 min to 60 min with knob or Disable by wire strap - on rear panel
Backlight	Continuous ON
Power Supply	115 or 230 Vac \pm 10% (user selectable); 60/50 Hz

Enclosure	Black anodized aluminum body; front and back with ABS; transparent splash-proof front cover
Environment	-10 to 50°C (14 to 122°F); RH 95%
Panel Cutout	141 x 69 mm (5.6 x 2.7")
Weight	1 kg (2.2 lb.)

SPECIFICATIONS HI 8936

Range	
HI 8936 A/AL	0.0 to 199.9 mS/cm
HI 8936 B/BL	0.00 to 19.99 mS/cm
HI 8936 C/CL	0 to 1999 μ S/cm
HI 8936 D/DL	0.0 to 199.9 μ S/cm
Resolution	
HI 8936 AL	0.1 mS/cm
HI 8936 BL	0.01 mS/cm
HI 8936 CL	1 μ S/cm
HI 8936 DL	0.1 μ S/cm
Accuracy (@20°C/68°F)	\pm 2% of Full Scale excluding probe error
Conductivity Probe	HI 7635 for in-line applications or HI 7638 for tank (not included)
Calibration	Manual, 2 point, through offset and slope trimmers
Temperature Compensation	Fixed or automatic from 0 to 50°C (32 to 122°F) with $\beta = 2\%/^{\circ}\text{C}$
Recorder output	4 to 20 mA not-isolated max. 500 Ohm
Protection	IP 65
Power Supply	
HI 8936 A/B/C/D	12 to 30 Vdc
HI 8936 AL/BL/CL/DL	17 to 36 Vdc
Environment	0 to 50°C (32 to 122°F); RH max 95%
Dimensions	165 x 110 x 71 mm (6.5 x 4.3 x 2.8")
Weight	1 kg (2.2 lb.)

CONNECTIONS

REAR CONNECTIONS FOR HI 8931

- **Power Connection Terminals**

4-screw-terminal-strip for connection to a 3-wire power cable according to the indicated voltage (115 or 230V).

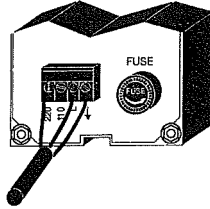

- **DIN connector socket**

For connection of the HI 7638 conductivity probe.

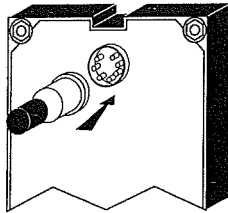

- **IN/OUT Transmitter**

2 wires of the 4-core signal cable from the conductivity transmitter (HI8936) have to be connected to the mA input terminals (7, 8) by paying attention to the polarity and the other 2 wires to the "+20 V" and "COM" while paying careful attention to the polarity (5, 6).

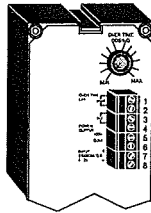

+20 V supply is the regulated DC supply required for the operation of the external conductivity transmitter HI 8936.

Note: Only one of DIN or input transmitter connectors can be used at a moment. Leave unconnected the unused input.

- **Set Contacts**

Dosing pumps or other control equipment may be connected to the "SET" (Max. 2A, 240 V) terminals (1, 2). These contacts act only as a "dry" switch allowing electrical continuity, not as a power supply.

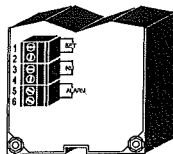

- **Set Select**

These contacts (4, 5) permit the activation of a Set Contact relay when the measured value is lower (connected terminals) or higher (open terminals) than the user's set value. See also page 24.

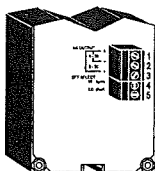

- **Recorder Output (terminals 1, 2, 3)**

These contacts are used for connection to a recorder output. The output can be 0-20 mA or 4-20 mA depending on the model and is proportional to the measured conductivity values.

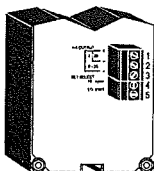

Connect the “+” wire from the recorder to terminal 1 on the instrument and the other wire (common) to terminal 2 for 4-20 mA recorder output or terminal 3 for 0-20 mA recorder output.

Note: Only one recorder output connection is permitted. In order to avoid damages leave unconnected the unused terminal.

- **Alarm Contacts (terminals 5, 6)**

During normal operation these terminals remain closed.

If the measured conductivity level is not within the tolerance of the set value, the alarm contact is open. These contacts act only as a switch. See also page 25.

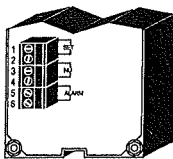

• Overtime dosing

When enabled this feature ensures that overdosage is avoided. Select a desired maximum dosage period. If the dosage relay is active more than the selected period an alarm condition is activated and the dosage relay is deactivated.

To set the overtime dosing period rotate the overtime knob to the proper position. The time can be set between approx. 5 min to 60 min (from MIN to MAX position).

To disable the overtime dosage feature make a short with a jumper wire between the terminals of the proper connectors. (see picture, terminals 1, 2)

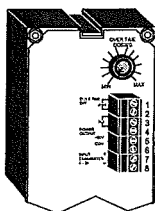

DOSING MODE SELECTION

The DOSAGE switch and the corresponding right side LED on the front panel are used to select and indicate the dosing mode.

OFF mode

The dosage is disabled. The corresponding DOSAGE MODE LED blinks.

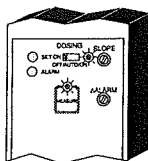

AUTO mode

The dosage is activated and deactivated according with the selected setpoint. The corresponding DOSAGE MODE LED (right side of the switch) is off.

Be sure that the DOSAGE switch is in AUTO position when the meter is in normal operating mode.

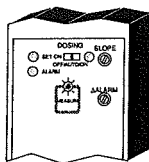

ON mode

The dosage is always activated. The corresponding DOSAGE MODE LED blinks.

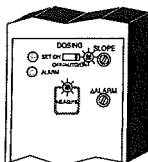

TERMINAL BOARD CONNECTIONS FOR H8936

- Remove the 4 screws and the top cover of the HI8936 conductivity transmitter to obtain access to the terminal board connections.

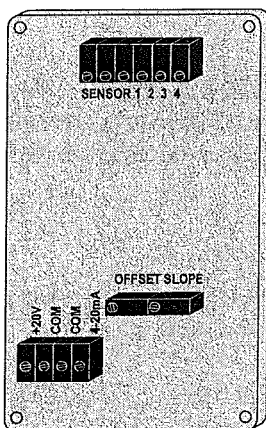
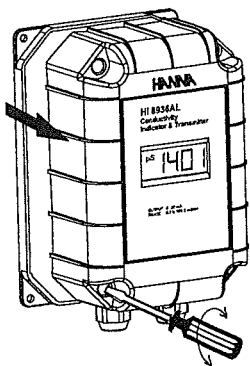

- HI 8936 used in conjunction with HI 8931 controller

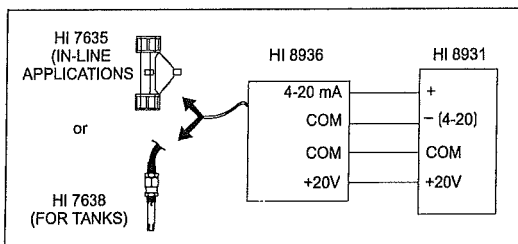

Use a PVC insulated 4-core cable to connect the transmitter to the HI 8931 conductivity controller (see also page 21).

The 4-core cable has to be connected to the transmitter according to the label instructions on the 4-terminal strip.

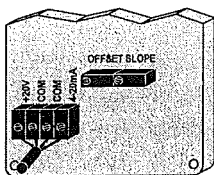

The regulated D.C. supply required for the proper operation of the transmitter is "+20 V", labeled "+20 V" and "COM". The current (mA) output terminals are labeled "4-20 mA" and "COM".

The transmitter is protected against inversion of supply voltage.

- **HI 8936 used in conjunction with an external power supply**

Use 2 PVC insulated 2-core cables.

Connect a +20 Vdc power supply directly to the terminals labeled "+20 V" and "COM", paying careful attention to polarity or if necessary in series with the receiving device.

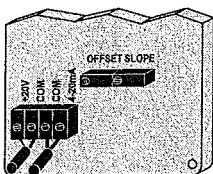

The regulated DC supply required for the proper functioning of the circuit is marked "+20 V" and "COM", and the transmitter current output is indicated "4-20 mA" and "COM".

The transmitter is protected against inversion of supply voltage.

Max. current required: 40 mA.

- **Use of an amplifier**

The maximum permissible distance between the power supply unit and the amplifier is 300 m (1000'). It is not necessary to use a shielded cable.

- **Probe Connection**

The conductivity probe is supplied with a 3 m (10'), 6 core cable. The cable is to be connected to the terminals provided (see also page 24 for proper connection scheme of HI 7635 and HI 7638).

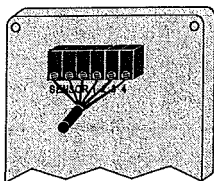

Note: All external cables connector to the rear panel should be ended with cable lugs.

CONDUCTIVITY PROBE CONNECTIONS

The connections for HI 7635 are color coded for easy installation and are as follows:

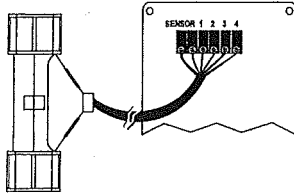

HI 7635 cable	HI 8936 transmitter
Black or Grey	NTC
Red or Pink	SENSOR
Brown or Orange	probe pin 1
Blue	probe pin 2
White	probe pin 3
Green or Yellow	probe pin 4

The connections for HI 7638 are as follows:

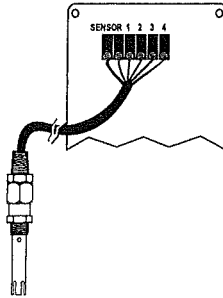

HI 7638	HI 8936 transmitter
#1	probe pin 1
#2	probe pin 2
#3	probe pin 3
#4	probe pin 4
#5	NTC
#6	SENSOR

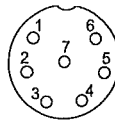

connector
inside view

Note: NTC & SENSOR are equivalent, and are both labeled "SENSOR" on the HI 8936 conductivity transmitter.

OPERATIONAL GUIDE

INITIAL PREPARATION & INSTALLATION

Material needed:

- a 3-wire power cable (to connect the HI 8931)
- a PVC insulated 4-core cable (to connect the HI 8931 to HI 8936)
- rubber seals and a pipe sealant (for installation of HI 7635)

INPUT FROM TRANSMITTER (HI8931 & HI8936)

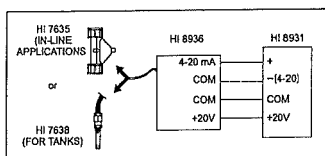

- Remove the 4 screws and the top of the HI 8936 conductivity transmitter.
- Connect the 2 wires connected to the "4-20mA" and "COM" terminals of the 4-core signal cable from the HI 8936 to the terminals marked "mA input" paying careful attention to polarity. Connect the other 2 wires to the "+ 20 V" and "COM" terminals, while paying attention to the polarity.
- Connect the 3-wire power cable to the 4-screw terminal strip according to the voltage level as indicated, and pay particular attention to the correct live, earth and neutral terminal connections.

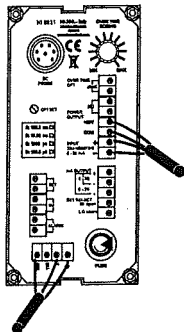
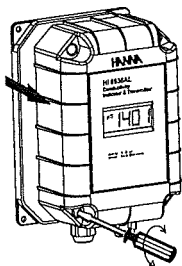

- The HI 8936 transmitter may be wall-mounted at any convenient location close to the measurement site.

To minimize thermal drifts due to extreme temperature fluctuations, particularly for outdoors measurements, it is recommended to protect the transmitter inside a casing.



- For the installation of the HI 7635 conductivity probe, use rubber seals between the probe and the pipe or elbow joints. A pipe sealant is also recommended to ensure a leak free joint. When screwing the joints, take care not to overtighten as excessive pressures can damage the probe.

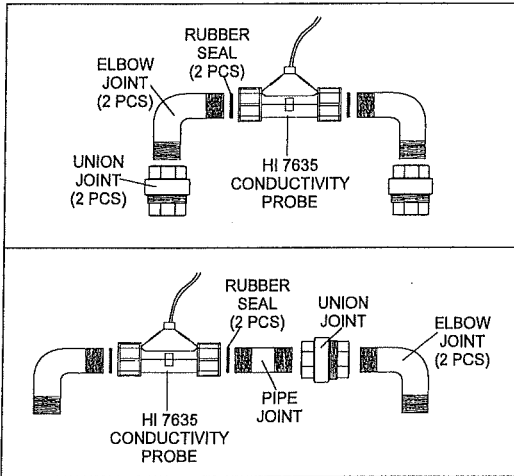

- The HI 7635 conductivity probe is supplied with a 3 m (10') cable. The 6-core cable of the probe is connected to the HI 8936 transmitter as shown.

The connections are color coded for an easy installation. See page 20 for the proper connection scheme.

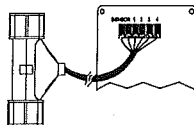

- It is recommended to install the **HI 7635** vertically. This is to ensure that trapped air bubbles or turbulent flows cause minimal interference to the measurement system. The maximum working pressure of this unit is 5 bar (72.5 psi).

WARNING: Do not use when temperature exceeds 80°C (176°F).

- The **HI 7638** process conductivity probe is also supplied with a 3 m (10') cable. The 6-core cable of this probe is connected to the **HI 8936** process conductivity transmitter as shown.

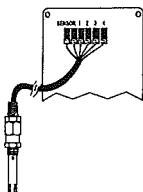

The DIN connector has to be removed when this probe is used in conjunction with an **HI 8936** transmitter. See page 20 for the proper connection scheme.

INPUT FROM PROBE

Ensure that the **HI 7638** conductivity probe is connected to the meter securely by aligning the pins with the socket, pushing the plug in and tightening the threaded ring.

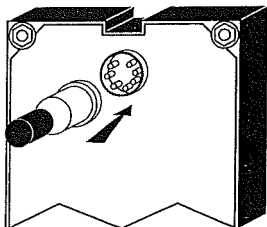

Note: Only one of DIN or INPUT TRANSMITTER connection can be used at a moment. Leave unconnected the other unused connection.

OPERATING INFORMATION

All parameters are set through the front panel keys and trimmers.

When any key is pressed, the corresponding LED lights up to indicate that the function is active.

Make sure that the conductivity meter, transmitter and probe are calibrated before taking measurements (see pages 28, 32 and 36 for calibration procedures).

SET POINT

To set the working point of the controller, press the SET key. The display will indicate the current set value.

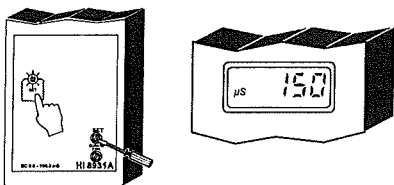

Use a small screwdriver to adjust the COARSE and FINE trimmers until the desired value is displayed.

Above Setpoint Control Operation

Leave the "SET SELECT" connectors "HI" and "LO" open. The set contacts relay will close if the measured value is higher than the setpoint value, and the "SET ON" LED will light up.

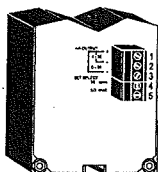

Below Setpoint Control Operation

Short the "SET SELECT" connectors "HI" and "LO" with a jumper wire. The set contact relay will close if the measured value is lower than the setpoint value, and the "SET ON" LED will light up.

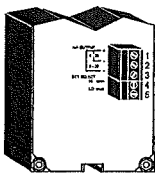

ALARM

Press the " Δ ALARM" key and the display will show the set tolerance for the alarm.

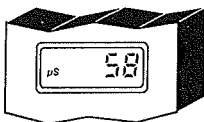

Use a small screwdriver to adjust the " Δ ALARM" trimmer until the desired tolerance is displayed.

For example, if the set value is $200 \mu\text{S}/\text{cm}$ and a Δ Alarm of $50 \mu\text{S}/\text{cm}$ is set, an alarm will be activated every time the measured value is higher than $250 \mu\text{S}/\text{cm}$ or lower than $150 \mu\text{S}/\text{cm}$.

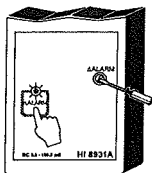

When an alarm occurs, the "ALARM" LED lights up.



The alarm contacts of HI 8931 remain closed during normal operation. If the measured conductivity level is not within the tolerance of the set value, the alarm contact will be open.

TAKING MEASUREMENTS WITH HI 8931

After setting the working point and alarm value, press the "MEASURE" key. The actual conductivity value of the test solution will be displayed.

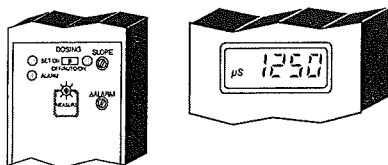

If the reading is out of range the instrument displays:

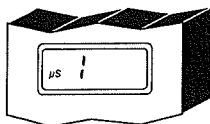

When Above Setpoint Control is selected (SET SELECT pins open) the SET ON LED lights up when the reading is higher than the setpoint.

When Below Setpoint Control is selected (SET SELECT pins short) the SET ON LED lights up when the reading is lower than the setpoint value.

When the dosage switch is in OFF or continuous ON position the corresponding LED blinks (the LED on the right side of the switch).

If the dosing switch is in OFF position the dosing and alarm relays are deactivated and the SET ON is OFF.

If the dosing switch is in ON position the DOSING relay is always activated and the SET ON LED lights up; the ALARM relay is activated and the ALARM LED blinks according with the input reading, setpoint and ALARM threshold.

If the dosing switch is in AUTO position, all relays are controlled depending on measure, setpoint and ALARM threshold.

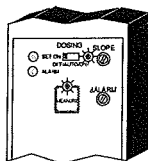

If overtime dosing function is enabled overtime OFF terminals (1,2) open and the DOSING switch is in AUTO or ON position, an ALARM is generated if the dosing time exceeds the overtime set period (overtime knob on the rear panel).

The dosing relay is not deactivated if the DOSING switch is in ON position but is deactivated if the switch is in AUTO position, when the overtime period is overpassed.

To leave overtime ALARM mode and return to normal operation move the DOSING switch in OFF and then in AUTO or ON position again. The dosage and alarm relays will be controlled depending on the measure, setpoint and alarm thresholds. The overtime counter is reinitialized to 0.

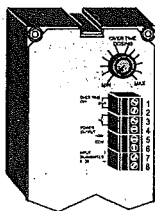

TAKING MEASUREMENTS WITH:

HI 8936AL, HI 8936BL, HI 8936CL, HI 8936DL

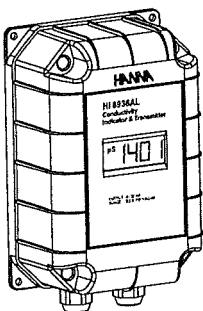

The conductivity transmitters with LCD will always display the measurement value when connected to the HI 8931 controllers or a power supply.

CALIBRATION PROCEDURE OF HI 8931 & HI 8936 WITH HI 7635

Material needed:

- HI 7635 conductivity probe
- HI 8931 conductivity controller
- HI 8936 conductivity transmitter
- A 20 mA f.s. ammeter (for transmitters without LCD)
- A reference conductivity meter with automatic temperature compensation accurately calibrated (e.g. HI 8733).

PROCEDURE

- Connect the HI 7635 probe to the HI 8936 transmitter (see page 21 for details).
- Connect the HI 8936 transmitter to the HI 8931 controller (see page 18 for details).
- Connect the HI 8931 controller to the mains (see page 21 for details).

Before proceeding with the calibration, make sure that the meter is in measurement mode ("MEASURE" LED is on) and not in set mode.



- Connect the ammeter to the HI 8936 transmitter to monitor the signal current (see below picture).

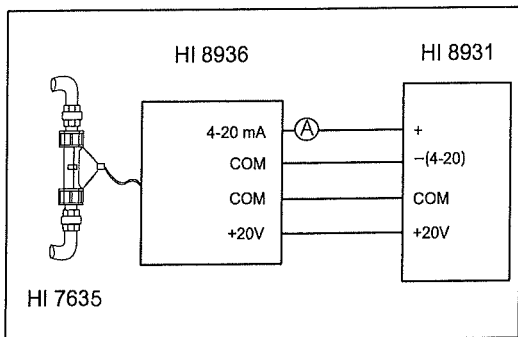

- Ensure that the HI 7635 conductivity probe is dry.
- When the power is on, the ammeter should read "4.0 mA". The HI 8936 transmitter with LCD should display "0".

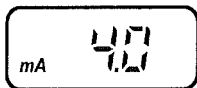

AMMETER

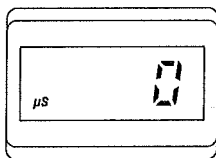

HI8936 WITH LCD

- If not, adjust the transmitter OFF-SET trimmer to read "4 mA" or "0" on the HI 8936 LCD.

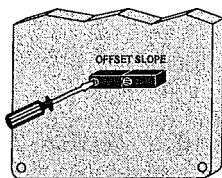

- The HI 8931 controller should display "0" value.

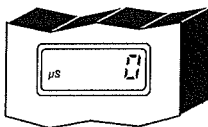

- If not, adjust the HI 8931 OFFSET trimmer on the rear panel to display a zero reading.

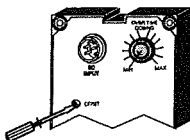

- Switch the flow on and allow the sample solution to flow through the HI 7635 conductivity probe. Collect a sample of this solution in a beaker.

- Measure the conductivity of the solution with a reference conductivity meter with ATC (HI 8733). The value obtained will be used for the transmitter and controller calibration.

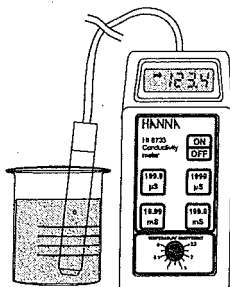

- The reading will be converted to mA by the following formula:

$$mA = K (\text{measured value} \times 16/2000) + 4$$

$$K = \text{conversion factor depending on the model}$$

Model	Conversion factor K
HI 8936 A/AL	10
HI 8936 B/BL	100
HI 8936 C/CL	1
HI 8936 D/DL	10

For example, using an HI 8936A, if the measured value is 123.4 mS, then
 output current = $10 \times (123.4 \times 16/2000) + 4 = 13.9 \text{ mA}$

Adjust the HI 8936 SLOPE trimmer to read "13.9 mA" on the ammeter, or the reading of the HI 8733 (e.g. 123.4 mS) on the HI 8936L display.

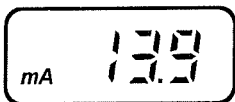
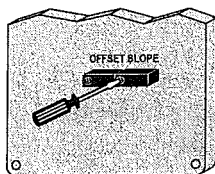

AMMETER

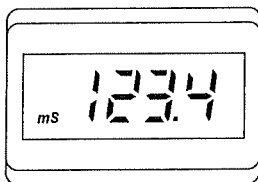

HI8936 WITH LCD

- Adjust the HI 8931 SLOPE trimmer until the controller reading is the same as the one displayed by the HI 8733 (e.g. 123.4 mS).

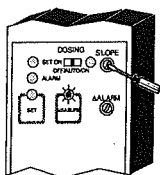

- The calibration is now complete and the instrument is ready for use. All subsequent measurements will be compensated to 25°C (77°F).
- If the instrument will not calibrate, refer to the "Probe Maintenance and Cleaning" section on page 46.
- If the HI 8936 is not used in conjunction with the HI 8931 controller, connect the transmitter to an external power supply (see page 19), to the HI 7635 conductivity probe (see page 20) and to an ammeter (see page 32).

The calibration of the transmitters with LCD (HI 8936L series) does not require an ammeter.

Follow the above calibration procedure performing the operations referred to the HI 8936 transmitter only.

CALIBRATION PROCEDURE OF HI 8931 & HI 8936 WITH HI 7638

Material needed:

- HI 7638 conductivity probe
- HI 8931 conductivity controller
- HI 8936 conductivity transmitter
- An ammeter (for transmitters without LCD)
- Calibration solutions, according to the different models:

HI 7034 80 mS/cm @25°C
for HI 8931A, HI 8936 A/AL

HI 7030 12.88 mS/cm @25°C
for HI 8931B, HI 8936 B/BL

HI 7031 1413 μ S/cm @25°C
for HI 8931C, HI 8936 C/CL

HI 7033 84 μ S/cm @25°C
for HI 8931D, HI 8936 D/DL

PROCEDURE

- Connect the HI 7638 to the HI 8936 transmitter (see page 20).
- Connect the HI 8936 transmitter to the HI 8931 controller (see page 18).
- Connect the HI 8931 controller to the mains (see page 21).

Before proceeding with the calibration, make sure that the meter is in measurement mode ("MEASURE" LED is on) and not in set mode.



- Connect the ammeter to the HI 8936 transmitter to monitor the signal current (see below picture).

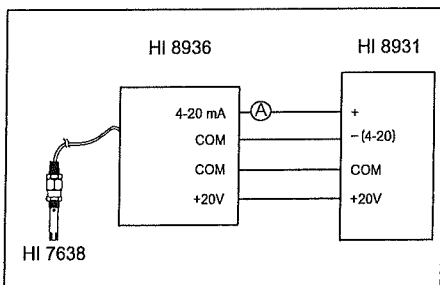

- Leave the HI 7638 conductivity probe in air (dry probe).



- When the power is on, the ammeter should read "4.0 mA" or the HI 8936 transmitter with LCD should display "0".

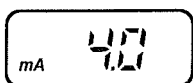

AMMETER

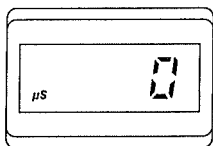

HI8936 WITH LCD

- If not, adjust the HI 8936 OFFSET trimmer to obtain "4 mA" or "0" on the HI 8936L.

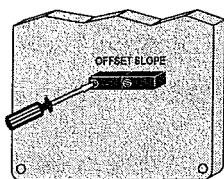

- The HI 8931 controller should display "0".



- If not, adjust the HI 8931 OFFSET trimmer on the rear panel to display a zero reading.

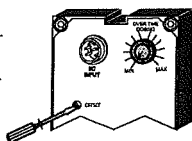

- Pour at least 8 cm (3¼") of conductivity solution into a plastic beaker.

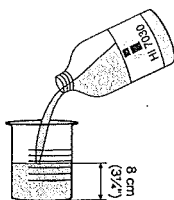

- Immerse the probe into the conductivity solution. The holes on the sleeve must be completely submerged in the solution.

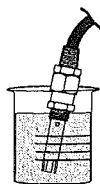

- Tap the probe repeatedly on the bottom of the beaker and stir it to ensure that no air bubbles remain trapped inside the sleeve.
- If the temperature of the probe is close to that of the solution, the display of HI 8931 will stabilize quickly and provide a temperature compensated conductivity measurement. Allow a few minutes if there is a temperature difference of about 5°C (9°F) or more for the ATC circuitry to compensate completely.

- **For HI 8936**

Adjust the SLOPE trimmer of the HI 8936 transmitter to read on the ammeter:

"10.4 mA" using HI 7034 and HI 8936 A/AL

"14.304 mA" using HI 7030 and HI 8936 B/BL

"15.304 mA" using HI 7031 and HI 8936 C/CL

"10.72 mA" using HI 7033 and HI 8936 D/DL

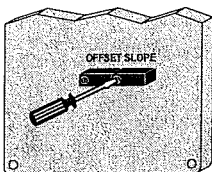

• FOR HI 8931

When the reading stabilizes, turn the SLOPE trimmer on the front of the HI 8931 until the LCD reading is the same as the calibration solution at 25°C (77°F), i.e.

"80.0 mS" using HI 7034 with HI 8931A

"12.88 mS" using HI 7030 with HI 8931B

"1413 μ S" using HI 7031 with HI 8931C

"84.0 μ S" using HI 7033 with HI 8931D

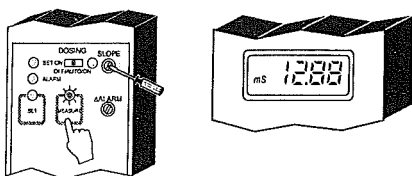

- The calibration is now complete and the instrument is ready for use. All subsequent measurements will be compensated to 25°C (77°F).
- If the instrument will not calibrate, refer to the "Probe Maintenance and Cleaning" section on page 46.
- If the HI 8936 is not used in conjunction with the HI 8931 controller, connect the transmitter to an external power supply (see page 19), to the HI 7638 conductivity probe (see page 20) and to an ammeter (see page 32).

The calibration of the transmitters with LCD (HI 8936L series) does not require any ammeter.

Follow the above calibration procedure performing the operations referred to the HI 8936 transmitter only.

CALIBRATION PROCEDURE OF HI 8931 WITH HI 7638

Material needed

- HI 7638 conductivity probe
- HI 8931 conductivity controller
- Calibration solutions, according to the different models:
HI 7034 80mS/cm @25°C for HI 8931A
HI 7030 12.88mS/cm@25°C for HI 8931B
HI 7031 1413 μ S/cm @25°C for HI 8931C
HI 7033 84 μ S/cm @25°C for HI 8931D

PROCEDURE

- Ensure that the probe is connected to the meter securely by aligning the pins with the socket, pushing the plug in and tightening the threaded ring.
- Insert the probe into the sleeve.
- With the conductivity probe in air, press the "MEASURE" key to set the meter to measurement mode.

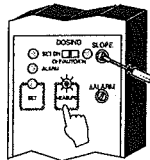
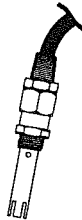
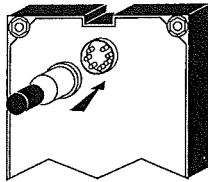

- If the LCD does not show "0", adjust the OFFSET trimmer on rear panel.

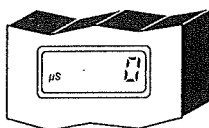
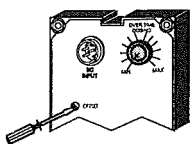

- Pour at least 8 cm (3¼") of conductivity solution into a plastic beaker.

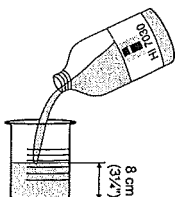

- Immerse the probe into the conductivity solution, while paying attention that the holes on the sleeve are completely submerged.
- Tap the probe repeatedly on the bottom of the beaker and stir it to ensure that no air bubbles remain trapped inside the sleeve.

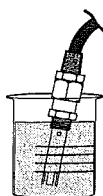

- If the temperature of the probe is close to that of the solution, the display will stabilize quickly and provide a temperature compensated conductivity measurement.

Allow a few minutes if there is a temperature difference of about 5°C (9°F) or more for the ATC circuitry to compensate completely.

- When the reading stabilizes, turn the SLOPE trimmer on the HI 8931 front panel until the LCD reads the same value of the calibration solution at 25°C (77°F), i.e.:

80.0 mS using HI 7034 with HI 8931A

12.88 mS using HI 7030 with HI 8931B

1413 μS using HI 7031 with HI 8931C

84.0 μS using HI 7033 with HI 8931D

- The calibration is now complete and the instrument is ready for use. All subsequent measurements will be compensated to 25°C (77°F).
- If the instrument will not calibrate refer to the "Probe Maintenance and Cleaning" section on page 43.

CONDUCTIVITY VERSUS TEMPERATURE CHART

°C	°F	HI7030 (mS/cm)	HI7031 (mS/cm)	HI 7033 (mS/cm)	HI 7034 (mS/cm)	HI7035 (mS/cm)	HI7039 (mS/cm)
0	32	7150	776	64	48300	65400	2760
5	41	8220	896	65	53500	74100	3180
10	50	9330	1020	67	59600	83200	3615
15	59	10480	1147	68	65400	92500	4063
16	60.8	10720	1173	70	67200	94400	4155
17	62.6	10950	1199	71	68500	96300	4245
18	64.4	11190	1225	73	69800	98200	4337
19	66.2	11430	1251	74	71300	100200	4429
20	68	11670	1278	76	72400	102100	4523
21	69.8	11910	1305	78	74000	104000	4517
22	71.6	12150	1332	79	75200	105900	4711
23	73.4	12390	1359	81	76500	107900	4805
24	75.2	12640	1386	82	78300	109800	4902
25	77	12880	1413	84	80000	111800	5000
26	78.8	13130	1440	86	81300	113800	5096
27	80.6	13370	1467	87	83000	115700	5190
28	82.4	13620	1494	89	84900	117700	5286
29	84.2	13870	1521	90	86300	119700	5383
30	86	14120	1548	92	88200	121800	5479
31	87.8	14370	1575	94	90000	123900	5575

If you are calibrating HI 8931A using HI 7030 (12.88 mS/cm @25°C) standard solution, turn the SLOPE trimmer to display "12.88 mS", with a reference temperature of 25°C (77°F), while for a reference temperature of 20°C (68°F), the SLOPE trimmer should be adjusted to display "11.67 mS".

DIAGNOSTIC TESTS

The HI 8931 controllers are designed with built-in diagnostic functions to enable the user to check and troubleshoot the instrument. The checks performed are through the front panel keys and can be used to isolate the cause of malfunction.

Press the "MEASURE" key before proceeding the following tests.

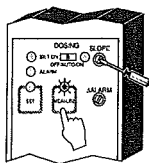

A) Test Offset

Press the "TEST OFFSET" key and the display should indicate the following values:

HI 8931	0.0 mS	± 1.0 mS
HI 8931	0.00 mS	± 0.10 mS
HI 8931	000 μ S	± 10 μ S
HI 8931	0.0 μ S	± 1.0 μ S

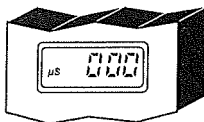
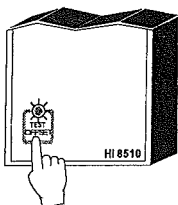

B) Test Slope

Press the "TEST SLOPE" key and the display should indicate the following values:

HI 8931	100.0 mS	± 35.0 mS
HI 8931	10.00 mS	± 3.50 mS
HI 8931	1000 μ S	± 350 μ S
HI 8931	100.0 μ S	± 35.0 μ S

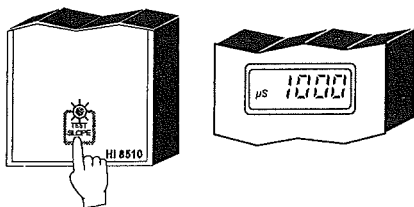

Note: The reading obtained by these functions will vary if the OFFSET and SLOPE trimmers on the front panel are adjusted.

INSTALLATION EXAMPLES

Some typical installation setups are shown in the following examples:

Example #1

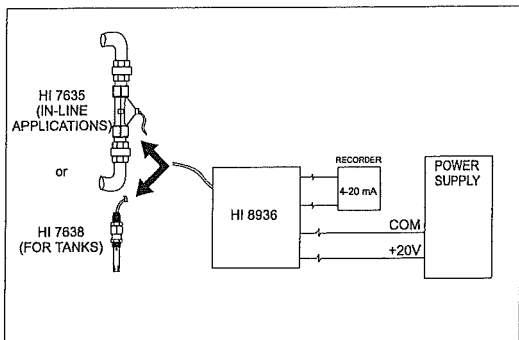

Example #2

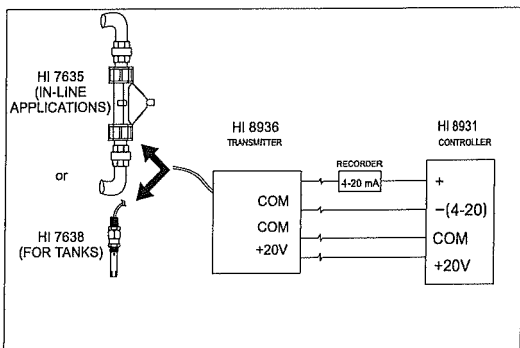

Example #3

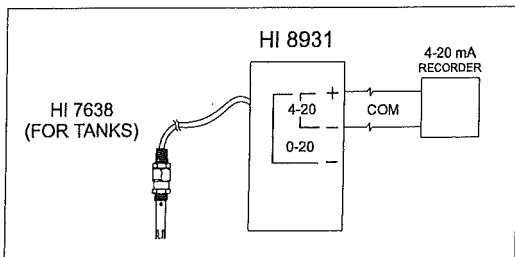

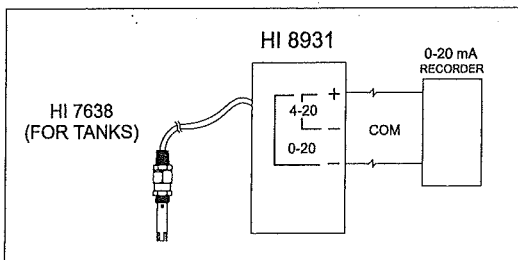

Example #4

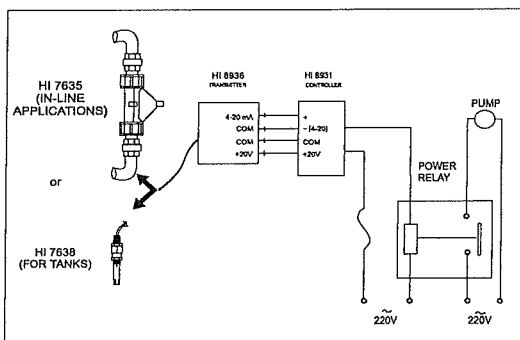

Example #5

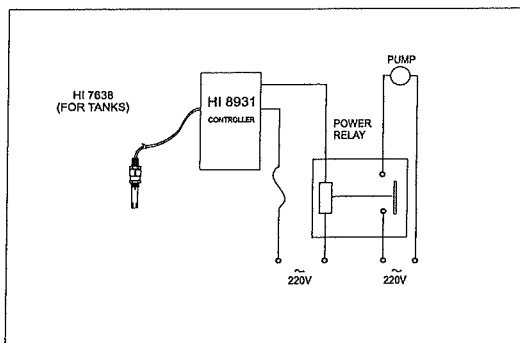

PROBE MAINTENANCE & CLEANING

The probe can be compensated for normal contamination by a process of re-calibration.

It is recommended to remove the probe from its installation regularly for maintenance.

For HI 7635 only:

Deposits on the conductivity probe can be removed by immersing the probe in 0.1 N hydrochloric acid for about 30 minutes. Heavier deposits may demand longer immersion periods.

Rinse the probe thoroughly with water prior to the reinstallation.

On reinstalling, check the seals carefully to ensure that a leak-free connection is obtained.

For HI 7638 only:

Rinse the probe with tap water. If a more thorough cleaning is desired, unscrew the plastic sleeve and clean the sensors with a nonabrasive cloth or alcohol.

After cleaning the probe, re-calibrate the instrument. If the instrument will not calibrate with a clean probe, you must replace the probe.

Note: Always re-calibrate the meter when attaching a new probe.

ACCESSORIES

CONDUCTIVITY CALIBRATION SOLUTIONS

HI 7030L	12880 $\mu\text{S}/\text{cm}$ calibration solution, 500 mL
HI 7030M	12880 $\mu\text{S}/\text{cm}$ calibration solution, 230 mL
HI 7031L	1413 $\mu\text{S}/\text{cm}$ calibration solution, 500 mL
HI 7031M	1413 $\mu\text{S}/\text{cm}$ calibration solution, 230 mL
HI 7033L	84 $\mu\text{S}/\text{cm}$ calibration solution, 500 mL
HI 7033M	84 $\mu\text{S}/\text{cm}$ calibration solution, 230 mL
HI 7034L	80000 $\mu\text{S}/\text{cm}$ calibration solution, 500 mL
HI 7034M	80000 $\mu\text{S}/\text{cm}$ calibration solution, 230 mL
HI 7035L	111800 $\mu\text{S}/\text{cm}$ calibration solution, 500 mL
HI 7035M	111800 $\mu\text{S}/\text{cm}$ calibration solution, 230 mL
HI 7039L	5000 $\mu\text{S}/\text{cm}$ calibration solution, 500 mL
HI 7039M	5000 $\mu\text{S}/\text{cm}$ calibration solution, 230 mL

OTHER ACCESSORIES

HI 731326	Calibration screwdrivers (20 pcs)
HI 779/P	6-wire cable (100 m/330' roll)
HI 8733	Portable conductivity meter with automatic temperature compensation

CONDUCTIVITY PROBES

HI 7635 In-line conductivity probe with 3 m (10') cable
(for HI 8936 only)

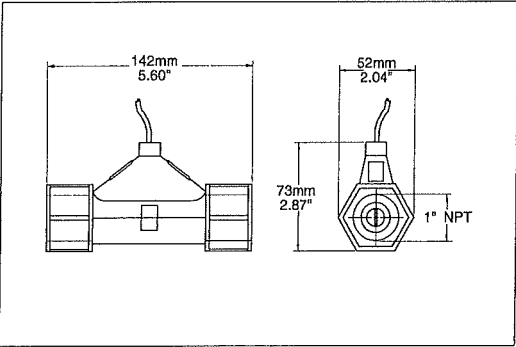

HI 7638 Conductivity probe for tank installation, with 3 m (10') cable
(for HI 8936 or HI 943500)

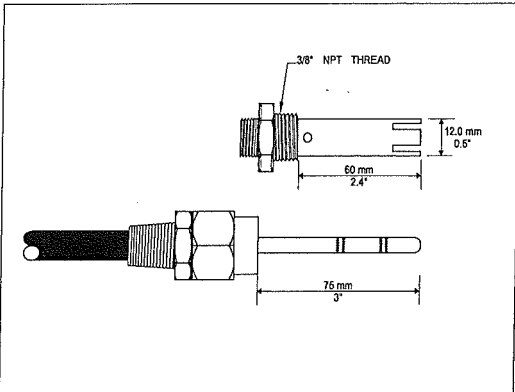

WARRANTY

All HANNA instruments® meters are warranted for two years against defects in workmanship and materials when used for their intended purpose and maintained according to instructions.

The probes are warranted for a period of six months.

This warranty is limited to repair or replacement free of charge.

Damages due to accident, misuse, tampering or lack of prescribed maintenance are not covered.

If service is required, contact the dealer from whom you purchased the instrument. If under warranty, report the model number, date of purchase, serial number and the nature of the failure. If the repair is not covered by the warranty, you will be notified of the charges incurred.

If the instrument is to be returned to HANNA instruments®, first obtain a Returned Goods Authorization Number from the Customer Service department and then send it with shipment costs prepaid.

When shipping any instrument, make sure it is properly packaged for complete protection.

All rights are reserved. Reproduction in whole or in part is prohibited without the written consent of the copyright owner.

Hanna Instruments reserves the right to modify the design, construction and appearance of its products without advance notice.

Recommendations for Users

Before using these products, make sure that they are entirely suitable for the environment in which they are used.

Operation of these instruments in residential area could cause unacceptable interferences to radio and TV equipments, requiring the operator to take all necessary steps to correct interferences.

The trimmers are sensitive to electrostatic discharges. It is recommended to use anti-static screwdrivers.

Unplug the instrument from the power supply before replacing the fuse. External cables to be connected to the rear panel should end with cable lugs.

To maintain the EMC performance of this equipment, use the recommended cables mentioned on this instruction manual.

Any variation introduced by the user to the supplied equipment may degrade the instruments' EMC performance.

To avoid electrical shock, do not use these instruments when voltages at the measurement surface exceed 24 Vac or 60 Vdc.

To avoid damages or burns, do not perform any measurement in microwave ovens.

SALES & TECHNICAL SERVICE CONTACTS

Australia:

Tel. (03) 9769.0666 • Fax (03) 9769.0699

China:

Tel. (10) 88570068 • Fax (10) 88570060

Egypt:

Tel. & Fax (02) 2758.683

Germany:

Tel. (07851) 9129-0 • Fax (07851) 9129-99

Greece:

Tel. (210) 823.5192 • Fax (210) 884.0210

Indonesia:

Tel. (21) 4584.2941 • Fax (21) 4584.2942

Japan:

Tel. (03) 3258.9565 • Fax (03) 3258.9567

Korea:

Tel. (02) 2278.5147 • Fax (02) 2264.1729

Malaysia:

Tel. (603) 5638.9940 • Fax (603) 5638.9829

Singapore:

Tel. 6296.7118 • Fax 6291.6906

South Africa:

Tel. (011) 615.6076 • Fax (011) 615.8582

Taiwan:

Tel. 886.2.2739.3014 • Fax 886.2.2739.2983

Thailand:

Tel. 66.2619.0708 • Fax 66.2619.0061

United Kingdom:

Tel. (01525) 850.855 • Fax (01525) 853.668

USA:

Tel. (401) 765.7500 • Fax (401) 765.7575

MAN8931

06/07

For e-mail contacts and complete list of Sales and Technical offices, please see www.hannainst.com