

GasAlertMicro 5 and GasAlertMicro 5 PID

O₂, CO, H₂S, PH₃, SO₂, Cl₂, NH₃, NO₂, HCN, ClO₂, O₃, VOC, and Combustibles

1, 2, 3, 4, and 5 Gas Detectors

User Manual

"INNOVATORS IN GAS DETECTION"

BW
Technologies

Limited Warranty & Limitation of Liability

BW Technologies LP (BW) warrants this product to be free from defects in material and workmanship under normal use and service for a period of two years, beginning on the date of shipment to the buyer. This warranty extends only to the sale of new and unused products to the original buyer. BW's warranty obligation is limited, at BW's option, to refund of the purchase price, repair, or replacement of a defective product that is returned to a BW authorized service center within the warranty period. In no event shall BW's liability hereunder exceed the purchase price actually paid by the buyer for the Product.

This warranty does not include:

- a) fuses, disposable batteries or the routine replacement of parts due to the normal wear and tear of the product arising from use;
- b) any product which in BW's opinion, has been misused, altered, neglected or damaged by accident or abnormal conditions of operation, handling or use;
- c) any damage or defects attributable to repair of the product by any person other than an authorized dealer, or the installation of unapproved parts on the product; or

The obligations set forth in this warranty are conditional on:

- a) proper storage, installation, calibration, use, maintenance and compliance with the product manual instructions and any other applicable recommendations of BW;
- b) the buyer promptly notifying BW of any defect and, if required, promptly making the product available for correction. No goods shall be returned to BW until receipt by the buyer of shipping instructions from BW; and
- c) the right of BW to require that the buyer provide proof of purchase such as the original invoice, bill of sale or packing slip to establish that the product is within the warranty period.

THE BUYER AGREES THAT THIS WARRANTY IS THE BUYER'S SOLE AND EXCLUSIVE REMEDY AND IS IN LIEU OF ALL OTHER WARRANTIES, EXPRESS OR IMPLIED, INCLUDING BUT NOT LIMITED TO ANY IMPLIED WARRANTY OF MERCHANTABILITY OR FITNESS FOR A PARTICULAR PURPOSE. BW SHALL NOT BE LIABLE FOR ANY SPECIAL, INDIRECT, INCIDENTAL OR CONSEQUENTIAL DAMAGES OR LOSSES, INCLUDING LOSS OF DATA, WHETHER ARISING FROM BREACH OF WARRANTY OR BASED ON CONTRACT, TORT OR RELIANCE OR ANY OTHER THEORY.

Since some countries or states do not allow limitation of the term of an implied warranty, or exclusion or limitation of incidental or consequential damages, the limitations and exclusions of this warranty may not apply to every buyer. If any provision of this warranty is held invalid or unenforceable by a court of competent jurisdiction, such holding will not affect the validity or enforceability of any other provision.

BW Technologies LP
2840 – 2nd Ave. SE
Calgary, AB
Canada T2A 7X9

BW America
3279 West Pioneer Parkway
Arlington, TX
USA 76013

BW Europe
101 Heyford Park,
Upper Heyford, Oxfordshire
United Kingdom OX25 5HA

Table of Contents

Title	Page
Introduction.....	1
Contacting BW Technologies.....	2
Safety Information - Read First.....	2
Getting Started.....	6
Activating the Detector.....	10
Self-Test.....	10
Self-Test Pass.....	17
Self Test Fail.....	17
Battery Test.....	17
Datalogger Operation.....	17
Deactivating the Detector.....	18
User Options Menu.....	18
Exit User Options Menu.....	19
Options Menu.....	19
Sensor Configuration.....	22
Logger Option.....	27
Clock Option.....	28
Language Selection.....	29
Tech Mode.....	30
Alarms.....	35
Gas Exposures Computed.....	38
Viewing Gas Exposures.....	38
Clearing Gas Exposures.....	39
Gas Alarm Setpoints.....	39
Viewing the Alarm Setpoints.....	39
Resetting Gas Alarm Setpoints.....	40
Stopping a Gas Alarm.....	41
Sensor Alarm.....	41
Pump Alarm.....	41

GasAlertMicro 5 and GasAlertMicro 5 PID

User Manual

Low Battery Alarm.....	42
Automatic Shutdown Alarm	42
Calibration and Setting Alarm Setpoints	42
Guidelines	42
Diagnostics Protection	43
Applying Gas to the Sensors	44
Calibration Procedure	44
Attaching the Accessories.....	57
Installing the Pump Module	57
Attaching the Sample Probe	58
Datalogger.....	59
Datalog.....	59
MultiMediaCard (MMC) Compatibility	60
Inserting the MMC/SD Card.....	60
MMC/SD Troubleshooting.....	61
Restoring Datalog Files	61
Reformatting the MMC.....	62
Import Datalogs to FleetManager.....	63
Minimum PC Requirements.....	63
Using MicroDock II to Import to FleetManager	63
Using a Card Reader to Import to FleetManager	63
View Datalog Files in Spreadsheets	64
Maintenance.....	68
Replacing/Charging the Batteries.....	68
Replacing a Sensor or Sensor Filter.....	69
Photoionization Detector (PID).....	71
Troubleshooting.....	73
Replacement Parts and Accessories	77
Specifications	79
Appendix A PID Correction Library	82

List of Tables

Table	Title	Page
1.	Gases Monitored	1
2.	International Symbols	5
3.	GasAlertMicro 5 and GasAlertMicro 5 PID Detector	7
4.	Display Elements	8
5.	Pushbuttons	9
6.	Alarms	35
7.	Computed Gas Exposures	38
8.	Gas Alarm Setpoints	39
9.	OSHA Sample Factory Alarm Setpoints	40
10.	Applying Gas to the Sensors	44
11.	Time Required to Span	47
12.	Installing the Pump Module	57
14.	Removing the MMC/SD Card	60
15.	Datalog Spreadsheet Example	65
16.	Datalog Status Codes	66
17.	Datalog Gas and Correction Factor Sensor Codes	67
18.	Replacing the Batteries	69
19.	Replacing a Sensor or Sensor Filter	70
20.	Parts of the PID sensor	71
21.	Troubleshooting Tips	73
22.	Replacement Parts and Accessories	77
23.	PID Corrections Factor (CF) Library	82

List of Figures

Figure Title	Page
1. GasAlertMicro 5 and GasAlert Micro 5 PID Detector	7
2. Display Elements	8
3. Applying Gas to the Sensors	44
4. Installing the Pump Module	57
5. Attaching the Sample Probe	58
6. Installing and Removing the MMC/SD	60
7. Replacing the Batteries	69
8. Replacing a Sensor or Sensor Filter	70
9. Parts of the PID	71

GasAlertMicro 5 and GasAlertMicro 5 PID

User Manual

CAUTION: FOR SAFETY REASONS, THIS EQUIPMENT MUST BE OPERATED AND SERVICED BY QUALIFIED PERSONNEL ONLY. READ AND UNDERSTAND THE INSTRUCTION MANUAL COMPLETELY BEFORE OPERATING OR SERVICING.

GasAlertMicro 5 Multi-Gas Detector

Standard instrument is equipped with integral concussion-proof boot and internal vibrator alarm.

GasAlertMicro 5 with User Downloadable Datalogger

Provides full-time continuous datalogging while the instrument is operating. Data is saved on a convenient MultiMediaCard (MMC) or secure digital (SD) card and can be removed and downloaded by the user. Data is imported into standard office software (Microsoft® Excel, Access etc.). Wraparound memory ensures the most recent data is always saved. Datalogging instruments include the Fleet Manager software.

Accessing Test Results with Fleet Manager

To access and view test results using the Fleet Manager software application, refer to the Fleet Manager Support CD.

GasAlertMicro 5

Introduction

Warning

To ensure your personal safety, read the [Safety Information](#) before using the detector.

The GasAlertMicro 5 gas detector (“the detector”) warns of hazardous gas at levels above user-selectable alarm setpoints.

The detector is a personal safety device. It is your responsibility to respond properly to the alarm.

Table 1 lists the gases monitored.

Table 1. Gases Monitored

Gas Detected	Unit of Measure
Oxygen (O ₂)	percent by volume (%)
Combustible gases field selectable for:	a) percent of lower explosive limit (% LEL) b) percent by volume methane 0-5.0% v/v
Carbon monoxide (CO)	parts per million (ppm)
Hydrogen sulfide (H ₂ S)	parts per million (ppm)
Phosphine (PH ₃)	parts per million (ppm)
Sulfur dioxide (SO ₂)	parts per million (ppm)
Chlorine (Cl ₂)	parts per million (ppm)
Ammonia (NH ₃)	parts per million (ppm)
Nitrogen dioxide (NO ₂)	parts per million (ppm)
Hydrogen cyanide (HCN)	parts per million (ppm)
Chlorine dioxide (ClO ₂)	parts per million (ppm)
Ozone (O ₃)	parts per million (ppm)
Volatile organic compounds (VOC)	parts per million (ppm)

Contacting BW Technologies

To contact BW Technologies, call:

USA: 1-888-749-8878

Canada: 1-800-663-4164

Europe: +44 (0) 1869 233004

Other countries: +1-403-248-9226

Address correspondence to:

BW Technologies LP
2840 – 2 Avenue S.E.
Calgary, AB T2A 7X9
CANADA

Email us at: info@bwt.net

Or visit us on the World Wide Web: www.gasmonitors.com

ISO 9001

Safety Information - Read First

Use the detector only as specified in this manual, otherwise the protection provided by the detector may be impaired.

International symbols used on the detector and in this manual are explained in Table 2.

Read the **Warnings** and **Cautions** on the following pages before using the detector.



This instrument contains batteries. Do not mix with the solid waste stream. Spent batteries should be disposed of by a qualified recycler or hazardous materials handler.

⚠ Cautions

- ⇒ **Warning:** Substitution of components may impair Intrinsic Safety.
- ⇒ **Caution:** For safety reasons, this equipment must be operated and serviced by qualified personnel only. Read and understand the user manual completely before operating or servicing.
- ⇒ Do not use the detector if it is damaged. Before using the detector, inspect the case. Look for cracks and/or missing parts.
- ⇒ If the detector is damaged or parts are missing, contact [BW Technologies](#) immediately.
- ⇒ Use only sensor(s) that are specifically designed for the GasAlertMicro 5 and the GasAlertMicro5 PID models. Refer to [Replacement Parts and Accessories](#).
- ⇒ Calibrate the detector before first-time use and then on a regular schedule, depending on use and sensor exposure to poisons and contaminants. BW recommends at least once every 180 days (6 months).
- ⇒ BW recommends to “bump test” the sensors before each day’s use to confirm their ability and response to gas by exposing the detector to a gas concentration that exceeds the high alarm setpoints. Manually verify that the audible and visual alarms are activated. Calibrate if the readings are not within the specified limits.
- ⇒ It is recommended that the combustible sensor be checked with a known concentration of calibration gas after any known exposure to contaminants/poisons (sulfur compounds, silicon vapors, halogenated compounds, etc.).
- ⇒ The combustible sensor is factory calibrated to 50% LEL methane. If monitoring a different combustible gas in the % LEL range, calibrate the sensor using the appropriate gas. High off-scale % LEL or % v/v methane readings may indicate an explosive concentration.
- ⇒ Only the combustible gas detection portion of this instrument has been assessed for performance by CSA International.





⚠ Cautions cont.

- ⇒ Protect the combustible sensor from exposure to lead compounds, silicones, and chlorinated hydrocarbons. Although certain organic vapors (such as leaded gasoline and halogenated hydrocarbons) may temporarily inhibit sensor performance, in most cases, the sensor will recover after calibration.
- ⇒ Any rapid up-scaling reading followed by a declining or erratic reading may indicate a gas concentration beyond upper scale limit, which may be hazardous.
- ⇒ Use only recommended AA alkaline or NiMH batteries that are properly charged and installed in the detector case. Refer to [Replacement Parts and Accessories](#).
- ⇒ Charge NiMH batteries using the recommended charger only. Do not use any other charger. Failure to adhere to this precaution can lead to fire and/or explosion.
- ⇒ Protect the PID sensor from exposure to silicone vapors.
- ⇒ The optional BW pump module (M5-PUMP) is certified for use with the GasAlertMicro 5 and the GasAlertMicro 5 PID only.
- ⇒ Read and adhere to all instructions and precautions in the literature provided with the charger. Failure to do so may result in fire, electric shock, personal injury, and/or property damage.
- ⇒ Extended exposure of the GasAlertMicro 5 and the GasAlertMicro 5 PID to certain concentrations of combustible gases and air may stress a detector element that can seriously affect its performance. If an alarm occurs due to high concentration of combustible gases recalibrate the sensor, or if required, replace the sensor.
- ⇒ Do not test the combustible sensor's response with a butane cigarette lighter; doing so will damage the sensor.
- ⇒ Do not expose the detector to electrical shock and/or severe continuous mechanical shock.

⚠ Cautions cont.

- ⇒ **Do not attempt to disassemble, adjust, or service the detector unless instructions for that procedure are provided in the manual and/or that part is listed as a replacement part. Use only BW Technologies [Replacement Parts and Accessories](#).**
- ⇒ **Do not immerse the detector in liquids.**
- ⇒ **The detector warranty will be voided if customer, personnel, or third parties damage the detector during repair attempts. Non-BW Technologies repair/service attempts void this warranty.**

Table 2. International Symbols

Symbol	Meaning
	Approved to both U.S. and Canadian Standards by the Canadian Standards Association
	European Explosives Protection
	Conforms to European Union Directives
BAM	BAM performance verification to European Performance Standards
ATEX	Conforms to European ATEX Directives
IECEX	International Electrotechnical Commission Scheme for Certification to Standards for Electrical Equipment for Explosive Atmospheres
	Type approved by ABS America for use aboard cargo vessels

Getting Started

The list below provides the standard items included with the detector. If the detector is damaged or parts are missing, contact the place of purchase immediately.

- Batteries: three replaceable alkaline cells or one rechargeable battery pack with the GasAlertMicro 5 Battery Charger
- Sensors: O₂, combustible (LEL), toxic, H₂S/CO (Twintox sensor), or PID
- Calibration hose and cap
- Screwdriver
- Quick reference guide
- Fleet Manager CD (if applicable)
- Manual and training CD

To order replacement parts, refer to [Replacement Parts and Accessories](#).

The detector is shipped with sensors and alkaline batteries installed. To replace the sensors and batteries, refer to [Maintenance](#).

To become oriented with the features and functions of the detector, refer to the following figures and tables:

- Figure 1 and Table 3 describes the detector's components
- Figure 2 and Table 4 describes the detector's Liquid Crystal Display (LCD) elements
- Table 5 describes the detector's pushbuttons

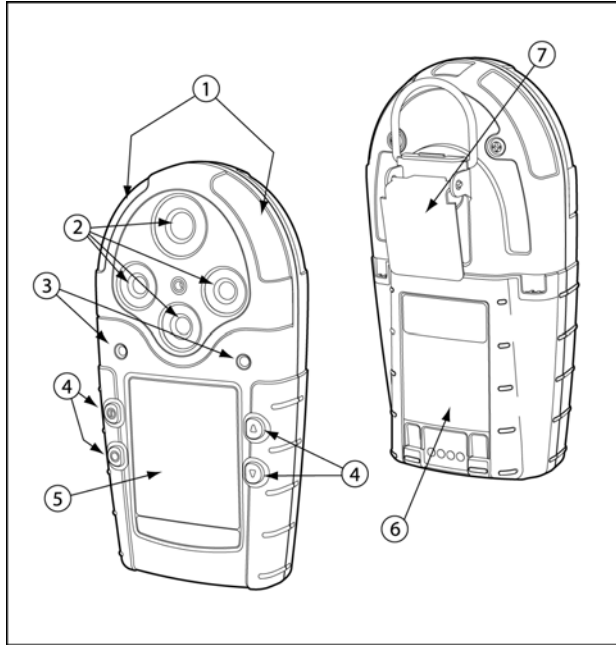

**Figure 1. GasAlertMicro 5 and GasAlert Micro 5 PID
Detector**

**Table 3. GasAlertMicro 5 and GasAlertMicro 5 PID
Detector**

Item	Description
1	Visual alarm bars (LED)
2	Sensors
3	Audible alarm
4	Pushbuttons
5	Liquid crystal display (LCD)
6	Battery pack
7	Alligator clip

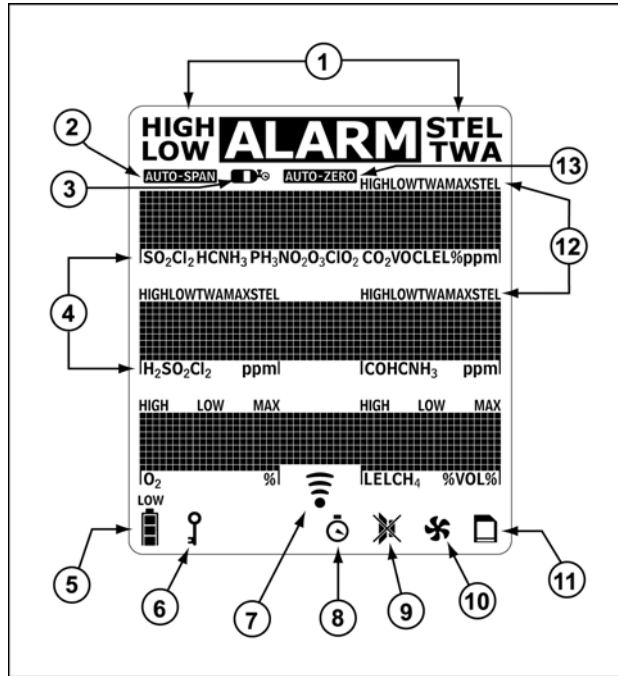

Figure 2. Display Elements

















Table 4. Display Elements

Item	Description
1	Alarm condition
2	Automatically span sensor
3	Gas cylinder
4	Gas identifier bars
5	Battery life indicator
6	Pass code lock
7	Data transmission
8	Clock
9	Stealth mode
10	Optional pump indicator
11	Optional datalogger card indicator
12	Alarm condition (low, high, TWA, STEL, or multi-gas) or view TWA, STEL, and maximum (MAX) gas exposures
13	Automatically zero sensor

Note

If enabled, the backlight automatically activates for 8 seconds when there is an alarm condition and whenever there is insufficient light to view the LCD. Any pushbutton reactivates the backlight in low-light conditions.

Table 5. Pushbuttons

Pushbutton	Description
	<ul style="list-style-type: none"> • To turn on the detector press . • To turn off the detector, press and hold  until the countdown is complete (from normal operation only).
	<ul style="list-style-type: none"> • To increment the displayed value or scroll up, press . • To enter the user options menu, press  and  simultaneously and hold until the countdown is complete. • To clear the TWA, STEL, and MAX gas exposure readings, press  and  simultaneously and hold until the countdown is complete. • To view the date and time, alarm setpoints (TWA, STEL, low, and high) of all sensors, and the LEL/PID correction factor (if applicable), press .
	<ul style="list-style-type: none"> • To decrement the displayed value or scroll down, press . • To initiate calibration and setting alarm setpoints, press  and  simultaneously and hold until the countdown is complete.
	<ul style="list-style-type: none"> • To view the TWA, STEL, and MAX hold readings, press . • To acknowledge latched alarms press .

Activating the Detector

Attach all of the accessories prior to activating the detector (e.g., pump module, sampling probe, hose, etc.). For illustrations and procedures, refer to [Attaching the Accessories](#).

To activate the detector, press  in a normal atmosphere (20.9% oxygen).

Self-Test

Once the detector is activated, it performs several self-tests. Confirm the following tests occur.

Note

If an error message displays during the self-test, refer to [Troubleshooting](#).

The detector performs a battery test during start-up.

If the battery has insufficient power to operate, the following screen displays before deactivating.

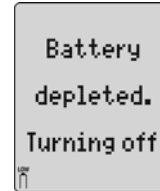

Replace the batteries and reactivate the detector.

1. All of the LCD elements display simultaneously as the detector beeps, flashes, vibrates, and briefly activates the backlight.

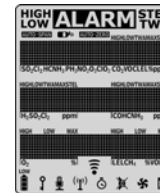

2. The version and serial number of the detector displays.



3. The date and time displays.

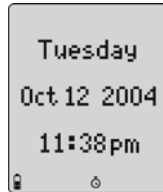

Datalogging Unit (Optional)

4. If the detector is a datalogging unit, it determines if
 - a MultiMediaCard (MMC) or secure digital (SD) card is inserted,
 - the detector can communicate with the card,
 - the detector supports the size of the card, and
 - the card requires formatting.

Note

*If there is a problem with the MMC/SD, **Datalogger disabled** displays. The detector then automatically continues with the self-test.*

If the card requires formatting, the following screen displays as the card is automatically formatted.



5. The detector then runs a self-test to verify the sensors and power supply.



Self-test Successful: If successful, the following screen displays.

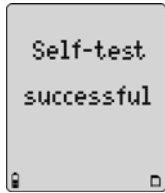

Self-test Unsuccessful: If a sensor fails the self-test, a warning displays indicating which sensor(s) has failed.

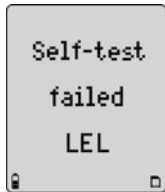

6. If correction factors are set in the user options, the LEL or PID (custom) correction factors display.

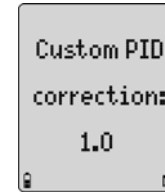
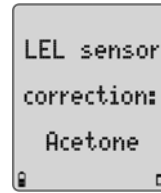

7. The TWA, STEL, low, and high alarm setpoints then display in the following order.

Note

The alarm setpoints may vary by region. Refer to [Resetting Gas Alarm Setpoints](#).

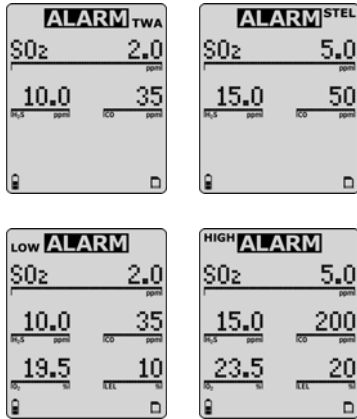

Pump Test (Optional)

8. If the pump module is attached to the detector, the following screens display.

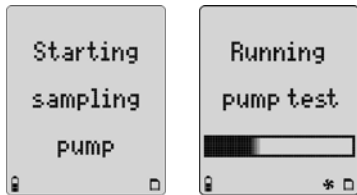

When the following screen displays, block the pump inlet.

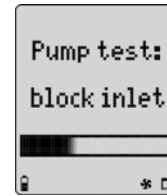

If the pump inlet is not blocked within 10 seconds or the pump test fails, the following screens display.

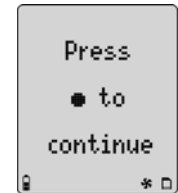
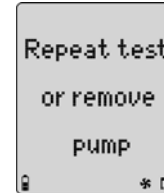
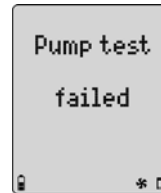

If is not pressed or the pump is not removed within 25 seconds, the detector performs the pump test again.

If the pump test is successful, the following screen displays and the self-test continues.

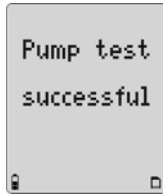

9. Unless disabled in user options, the oxygen (O_2) sensor is calibrated automatically.

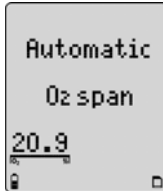

If the span is successful, the detector beeps twice.

Note

If the automatic O_2 calibration feature has been disabled, **Automatic O_2 span disabled** displays.

10. Lastly, the number of days remaining before calibration is due displays for all sensors.

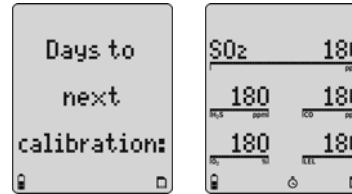

If any sensor is past due for calibration, the name of the sensor and the number of days past due display.

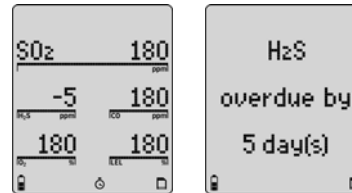

Note

If any sensor is overdue,  displays continually until calibration is performed.

The self-test is now complete. If **Due-lock** is disabled, the detector enters normal operation.

Due-Lock Is Enabled

The **Due-lock** option is used to ensure that a passcode must be entered when calibration is past due, otherwise the detector automatically deactivates.

If no passcode is entered, or it is entered incorrectly, the following screen displays.

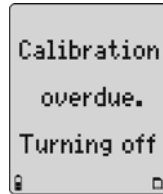

To enable this option, refer to [Due-lock](#) in the options menu. Also refer to [PassCode Protect](#).

Force Calibration Is Enabled

If **Force cal** is enabled in the user options menu, calibration is mandatory before the detector enters normal operation. Refer to [Force Calibration](#) in [Tech Mode](#) to enable/disable, and refer to [Calibration and Setting Alarm Setpoints](#) for calibration procedures.

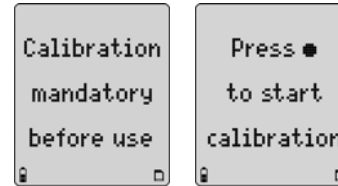

If is not pressed to start calibration, the following screen displays and the detector deactivates.

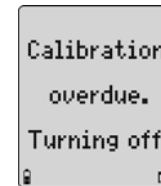

Daily Bump

If the [Bump Daily](#) (**Bmp daily**) option is enabled from [Tech Mode](#), the following bump test mandatory screen displays.

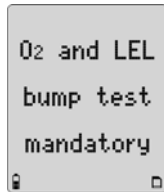

The mandatory daily bump test is applicable only to the LEL and O₂ sensors. The bump test must be performed otherwise the detector will deactivate.

11. When the following screen displays, apply the test gas. Ensure the cylinder icon is flashing before applying gas.

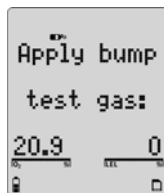

Note

If the bump test is not performed, the detector deactivates.

Successful Bump Test: If the bump test passes, the following screens display.

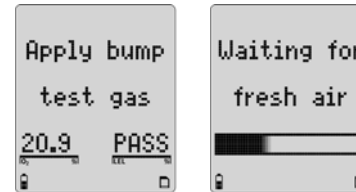

The detector waits for the sensor(s) to clear (approximately 30 seconds) and then enters normal operation.

Unsuccessful Bump Test: If the bump test is unsuccessful or the bump test is not performed, the following screen displays and the detector deactivates.

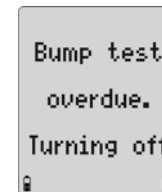

Self-Test Pass

If the detector passes the self-test, it enters normal operation displaying the ambient gas readings.



The detector begins recording the maximum gas exposure (MAX) and calculating the short-term exposure level (STEL) and time-weighted average (TWA) exposures.

Self Test Fail

If a sensor fails, **FAIL** displays above that sensor on the normal operating screen. For possible reasons and solutions, refer to [Troubleshooting](#).

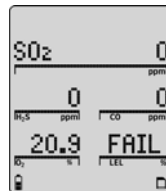

Battery Test

The batteries are tested when the detector is activated and continuously thereafter. The battery power icon displays continually during normal operation. If battery power is low,  flashes.

Datalogger Operation

⚠ Caution

Do not remove the battery pack while the detector is activated. Doing so will prevent the datalogger from logging correctly.

Datalogger operation is automatic and requires no settings. During normal operation the card is tested every 20 seconds.

Note

The MMC/SD icon  displays continuously on datalogger detectors when the card is inserted. The card is not required for operation of a detector equipped with datalogging.

Deactivating the Detector

To deactivate the detector, press and hold  while it beeps and flashes to the corresponding countdown.

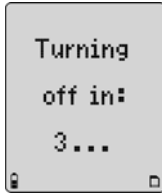

At the end of the countdown the detector emits an extended beep and flash, and displays **0** before deactivating.

Note

If  is not held down for the complete countdown, the detector remains activated.

User Options Menu

If the detector is passcode protected, a passcode must be entered to access the user options menu. For more information, refer to [Passcode Protect](#).

The available user options are as follows:

1. **Exit;**
2. **Options:** backlight, confidence beep, due-lock, latch, passcode, safe, and fast pump;
3. **Sensors:** sensor enable/disable, span gas, STEL period, TWA method, resolution, % vol CH₄, correction factor, and automatic O₂ calibration;
4. **Logger;**
5. **Clock;**
6. **Language:** English, French, German, Spanish, and Portuguese;
7. **Tech mode:** sensors, pump, initialize, forced calibration, daily bump test, and stealth.

Note

Tech mode is not visible in the user options menu. To access this option, refer to [Tech Mode](#).

To enter the user options menu, press and hold ▲ and ▼ simultaneously as the detector beeps and flashes to the corresponding countdown.

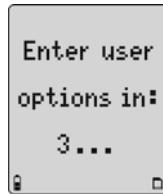

▲ and ▼ must be held down for the entire countdown to enter the user options menu.

When the countdown is complete, the revision/serial number screen displays followed by the options menu.

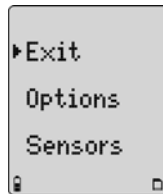

To scroll through the options, press ▼ or ▲. When the cursor displays beside the desired option, press ○.

To return to the previous menu, scroll to **Back** and press ○ or press Ⓞ.

Note

If no pushbuttons are pressed for 20 seconds, the detector returns to normal operation.

Exit User Options Menu

To exit the user options menu and return to normal operation, scroll to **Exit** and press ○. The following screen displays.

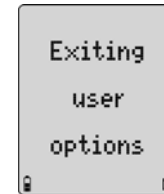

Note

The user options menu can also be exited by repeatedly pressing Ⓞ until the detector returns to normal operation.

Options Menu

Each feature within the **Options** menu is enabled/disabled by pressing ○ to toggle the checkbox.

Enabled	<input checked="" type="checkbox"/>
Disabled	<input type="checkbox"/>

Backlight

The backlight (**Backlight**) option is used to enable the LCD backlight to activate automatically in low-light conditions.

If disabled, the backlight is activated only when the detector is in alarm mode.

The detector is shipped with the backlight option enabled.

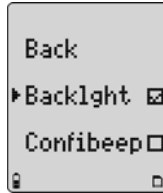

Confidence Beep

The confidence beep (**Confibeep**) option is used to provide continuous confirmation that the detector is operating properly. When confidence beep is enabled, the audible alarm beeps once every 10 seconds.

The detector is shipped with the confidence beep option disabled.

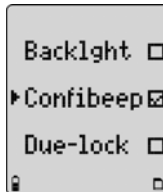

Due-Lock

If **Due-lock** is enabled and a sensor is overdue for calibration upon start-up, the passcode must be entered to access normal operation. If the correct passcode is not entered, the detector deactivates.

The detector is shipped with the due-lock option disabled.

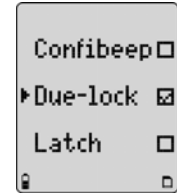

Latched Alarms

If enabled, the latched alarms (**Latch**) option causes the low and high gas alarms (audible, visual, and vibrator) to persist until they are acknowledged. Press \bigcirc to acknowledge the alarm.

The detector is shipped with the latch option disabled.

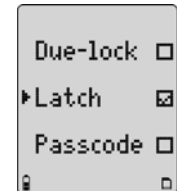

Passcode Protect

The passcode option is used to prevent unauthorized access to the user options menu, the calibration function, and to adjusting the alarm setpoints.

Note

The passcode is provided separately.

If passcode protect is enabled and the **Enter passcode: 1000** screen displays, press ▲ or ▼ to scroll to the correct passcode and then press ○ to confirm.

The detector is shipped with the passcode protect option disabled.

If an incorrect passcode is confirmed or ○ is not pressed within 5 seconds to confirm the correct passcode, **Passcode incorrect** displays. The alarm beeps three times and the detector either resumes normal operation or deactivates.

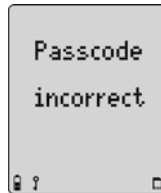
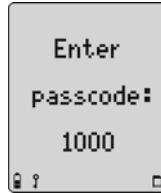
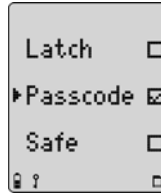

Safe Display

When enabled, the safe option confirms that normal ambient conditions prevail and there are no gas hazards present. When all gas levels are normal or below the alarm setpoints, **Safe** displays continually on the LCD.

The detector is shipped with the safe option disabled.

Fast Pump (Applicable to Pump Module Only)

If the pump module (optional accessory) is attached to the detector, and the sampling hose is longer than 50 ft., the **Fast pump** option must be enabled for maximum flow rate. The detector is shipped with the fast pump option disabled. If enabled, the battery life will deplete sooner.

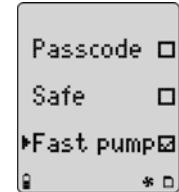
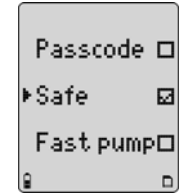

Sensor Configuration



The **Sensor** options provide access to additional options and functions that are available for each sensor.

Depending upon the sensor that is selected, some or all of the following options are available for configuration:

- enabling/disabling a sensor
- setting the span gas value
- adjusting the STEL period (not applicable to LEL and O₂ sensors)
- selecting the TWA method (not applicable to LEL and O₂ sensors)
- resolution setting (not applicable to CO, LEL, and O₂ sensors)
- % vol CH₄ (LEL sensor only)
- Selecting the correction factor (LEL and PID sensors only)
- automatic calibration (O₂ sensor only)

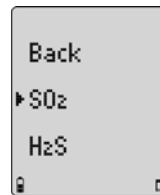
From the option menu screen, scroll to **Sensors** and press  to access the following screen.



Press  or  to scroll to the desired sensor. Press  to confirm and to access the menu options that are specific to the selected sensor.

For all sensor options, if a value is changed but not confirmed within 5 seconds, the detector emits an audible alarm and displays the following error message.

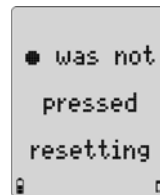

The detector retains the previous value and returns to the user options menu.

Sensor Enable/Disable

⚠ Warning

Disabling an installed sensor configures the detector to a 1, 2, 3, or 4-gas unit. Protection is no longer provided from the gas targeted by the disabled sensor(s). Disabling a sensor should be performed with extreme caution.

If a sensor fails, disabling the sensor deactivates the fail alarm. The sensor should be replaced and enabled as soon as possible. The detector will function normally with the remaining enabled sensors.

After selecting the desired sensor, the following screen displays.

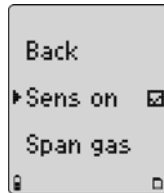

Press to toggle between enable/disable.

Enabled A sensor can be enabled at any time.

Disabled

If disabled, the readings for the sensor do not display when in normal operation.

If a sensor is enabled but it is not installed in the detector, **FAIL** displays above the gas bar of the missing sensor.

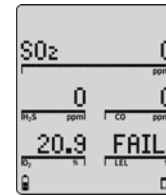

If all of the sensors are disabled, the following screens display.

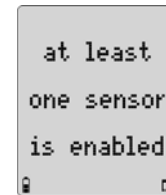
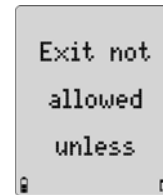

Enable one or more sensors to exit and access normal operation.

Span Gas Value

The **Span gas** option is used to increase/decrease the gas concentration level for calibration (it must match the value on the gas cylinder).

After selecting the sensor, press \blacktriangledown to scroll to **Span gas** and press \bigcirc within 20 seconds to confirm.

Depending upon the sensor selected, a screen similar to one of the two following examples displays. Press \blacktriangle or \blacktriangledown to scroll to the desired value and press \bigcirc within 5 seconds to confirm.

If \bigcirc is not pressed within 5 seconds to confirm the new value, the detector retains the previous value and returns to the user options menu.

Note

BW recommends that span concentration values be set between specific ranges. Refer to the [Calibration and Setting Alarm Setpoints](#).

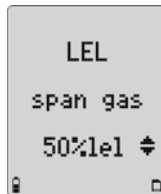
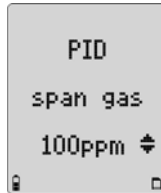
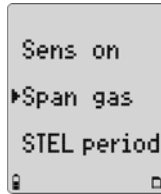

STEL Period

The **STEL period** option is available for every toxic sensor.

After selecting the desired sensor, press \blacktriangledown to scroll to **STEL period** and press \bigcirc within 20 seconds to confirm.

The STEL period can be set from 5 to 15 minutes. Press \blacktriangle or \blacktriangledown to scroll to the required value, and then press \bigcirc within 5 seconds to confirm.

If \bigcirc is not pressed within 5 seconds to confirm the new value, the detector retains the previous value and returns to the user options menu.

The detector is shipped with the STEL calculation period set to 15 minutes.

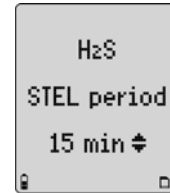
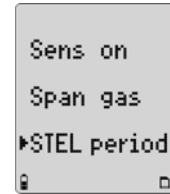

TWA Method

The **TWA** method is used to select either the Occupational Safety and Health Administration (OSHA) or the American Conference of Governmental Industrial Hygienists (ACGIH) calculating method.

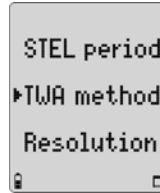

OSHA Method: 8 hour moving average.

ACGIH Method: Infinite accumulated average to 8 hours.

After selecting the desired sensor, press \blacktriangledown to scroll to **TWA method**. Press \bigcirc within 20 seconds to confirm.

A check displays in the checkbox of the currently selected method. To select the other method, press \blacktriangledown to move the check to other method. Press \bigcirc to confirm the selection.

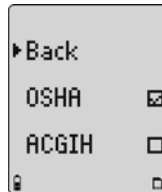

The detector is shipped with the **OSHA** method enabled.

Note

If the TWA method has been changed, the TWA, STEL, and MAX peak values must be reset to ensure the TWA is calculated correctly. Refer to [Clearing Gas Exposures](#).

Resolution

This option is used to display the gas measurement using **Regular** or **Extra** resolution.

Regular: Displays gas measurement in 1 ppm.

Extra: Displays the gas measurement in 0.1 ppm.

After selecting the desired sensor, press \blacktriangledown to scroll to **Resolution**. Press \bigcirc within 20 seconds to confirm.

A check displays in the checkbox of the currently selected resolution. To select the other resolution, press \blacktriangledown to move the check to other resolution. Press \bigcirc to confirm the selection.

The detector is shipped with **Regular** resolution (1 ppm) enabled.

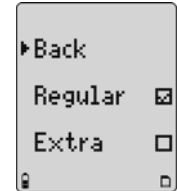
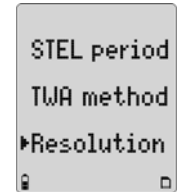



Note

Regular resolution for O₃ and ClO₂ sensors is 0.1 ppm, while extra resolution is 0.01 ppm. CO, O₂, LEL, and PID sensors do not have resolution settings.

% Vol CH₄ (LEL Sensors Only)

If the % vol is enabled, any currently enabled correction factor is ignored and the detector operates assuming a methane (CH₄) calibration.

After selecting the LEL sensor, press  to scroll to % vol CH₄. Press  within 20 seconds to confirm.

Press  to toggle between enable and disable.

Confirmation is not required. If no buttons are pushed, after 20 seconds the detector returns to the sensor selection screen. The change is saved automatically.

The detector is shipped with %vol disabled.

Correction Factor (CF)

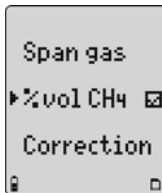
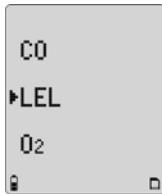

Depending upon the selected sensor, refer to the following sections [LEL Sensor](#) or [PID Sensor](#) for more information.





Enable
Disable





LEL Sensor

This option is used to enter compensation factors for hydrocarbons other than methane. The factor can only be applied if the LEL sensor has been calibrated with methane.

After selecting the LEL sensor, press  to scroll to **Correction**. Press  within 20 seconds to confirm and access the LEL correction library.

Scroll to the required gas type and press . A check mark displays in the corresponding checkbox. The detector automatically applies the correction factor.

To disable the **Correction** option, press  to scroll to **None** or to **Methane**. A checkmark displays. If required, select a different gas type correction factor.

Custom: To enter a correction factor that is not listed in the library, scroll to **Custom** and press  to confirm. The **Custom LEL correction** screen displays. Press  or  to select the required value, and press  within 5 seconds to confirm.

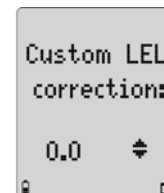
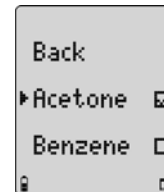
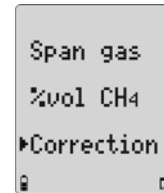

PID Sensor

This option is used to enter compensation factors for selected gas types. The factor can only be applied if the PID sensor has been calibrated with isobutylene.

After selecting the **PID** sensor, press \blacktriangledown to scroll to **Correction**. Press \bigcirc within 20 seconds to confirm and access the PID correction library.

Scroll to the required gas type and press \bigcirc . A check mark displays in the corresponding checkbox. The detector automatically applies the correction factor.

To disable the **Correction** option, press \blacktriangledown to scroll to **None** or to **Isobutyl**. A checkmark displays. If required, select a different gas type correction factor.

Custom: To enter a correction factor for a custom PID sensor, scroll to **Custom** and press \bigcirc . Press \blacktriangle or \blacktriangledown to scroll to the required value, and press \bigcirc within 5 seconds to confirm. Refer to [Appendix A PID Correction Factor Library](#) for gas types and corresponding correction factor values.

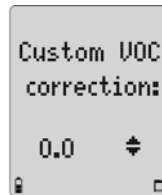
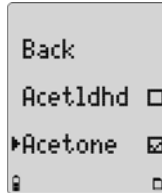
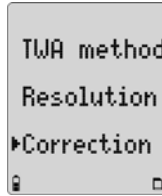

Automatic Oxygen (O₂) Calibration

When the **Autocal** option is enabled, it forces the detector to automatically calibrate the oxygen sensor during start-up.

If the **Autocal** option is enabled, ensure the detector is activated in a clean atmosphere only.

From the **Sensor** menu, press \blacktriangledown to scroll to **O₂** and press \bigcirc within 20 seconds to confirm.

Press \blacktriangledown to scroll to **Autocal**. Press \bigcirc to toggle between enable/disable.

The detector is shipped with the **Autocal** option enabled.

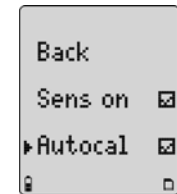
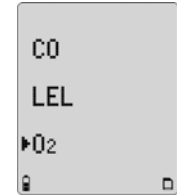

Logger Option

This option is used to set how often the detector records a datalog sample (once every 1 to 127 seconds).

From the user options menu, press \blacktriangledown to scroll to **Logger**. Press \bigcirc within 20 seconds to confirm.

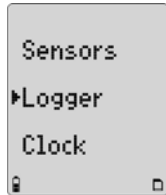

Press \blacktriangle or \blacktriangledown to change the current logger rate. When the desired value displays, press \bigcirc within 5 seconds to confirm the new value.

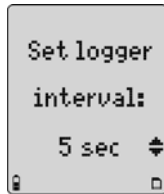

If \bigcirc is not pressed within 5 seconds, the following screen displays.

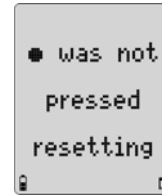

The detector is shipped with the datalogger interval set to 5 seconds.

Clock Option

The **Clock** option is used to set/change the date and time.

From the user options menu, press \blacktriangledown to scroll to **Clock**. Press \bigcirc within 20 seconds to confirm.

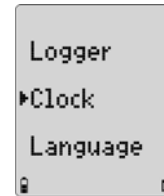

The screen displays showing the month highlighted indicating it is selected to set.

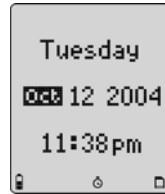

Press or to scroll to the desired month and press within 20 seconds to confirm. Continue setting the remaining options.

The date/time options are set as follows:

month
day
year
hour
minutes

To bypass and retain the current setting, press .

When the settings are complete, the detector beeps twice and returns to the user options menu.

The detector is shipped with the date and time set to Mountain Standard Time (MST).

Language Selection

The detector is shipped with English as the default language. The available languages to select from are as follows:

- French (**Français**)
- German (**Deutsch**)
- Spanish (**Español**)
- Portuguese (**Prtuguês**)

Press to scroll to **Language** and press within 20 seconds to confirm.

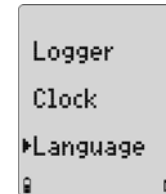

Press or to scroll to the desired language and press . A checkmark displays in the checkbox of the selected language.

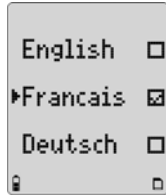

Press **▲** to scroll to **Back** or wait for 20 seconds until the detector returns to the user options menu. The screens now display in the selected language.

Tech Mode

⚠ Warning

Tech mode should only be accessed by trained personnel.

Tech mode can only be accessed from the **Language** option. Press **▼** to scroll to **Language**. Do not press **○** until instructed.

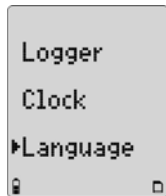

In the following order, press and continue to hold each button until **Tech mode** displays.

1. Press and hold **▼** with right index finger.
2. Press and hold **▲** with right middle finger.
3. Press and hold **○** with left thumb.

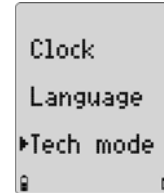

Press **○** to enter **Tech mode**. The options are as follows:

- **Sensors**
- **Pump**
- **Initialize**
- Force calibration (**Force cal**)
- Bump test daily (**Bmp daily**)
- Stealth mode (**Stealth**)
- IR Stealth mode (**IR Stlth**) / optional feature

Sensors

⚠ Caution

Physically change the sensor prior to entering Tech Mode to reconfigure the sensor type.

When a toxic sensor is physically removed and replaced by another toxic sensor, the detector must be reconfigured to recognize the change.

Press **▼** to scroll to **Sensors**. Press **○** within 20 seconds to confirm and access the toxic sensor menu.



Press **▲** or **▼** to scroll to **Toxic 1** or **Toxic 2** and press **○** within 20 seconds to confirm.

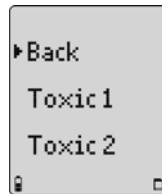

A corresponding list of toxic sensors displays. A checkbox displays beside the current toxic sensor.

Note

The **Toxic 1** list includes the PID sensor. The **Toxic 2** list includes the H₂S/CO COSH sensor.

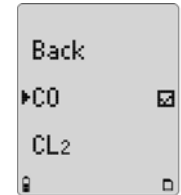

Press **▲** or **▼** to scroll to the new sensor and press **○** to confirm. A checkbox displays beside the new sensor. To reconfigure, exit the user options menu.

The following screen displays. The detector deactivates and immediately reactivates. It performs the reconfiguration during the start-up.

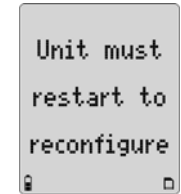



The new sensor must also be calibrated as the calibration information returns to the default settings, and the due date automatically displays as **OL** (over limit) while in normal operation.

Pump (Optional Accessory)



Warning

Use only the pump that is provided with the detector. Do not exchange pump modules between detectors.

If the detector has been purchased with the pump, the settings do not need to be adjusted. If attaching a new pump module to the detector, the flow rate must be set prior to using the pump.

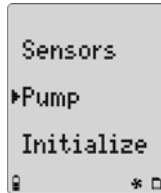
If required, refer to [Installing the Pump Module](#). Press  to scroll to **Pump** and press  within 20 seconds to confirm.



Press  and  to scroll to the required factory-calibrated value (as provided by BW). When the value displays, press  within 5 seconds to confirm.

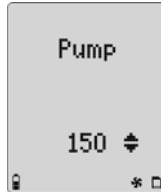

After selecting a new flow rate, a pump test must be performed.

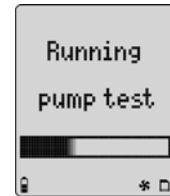

Exit the user options menu. The detector automatically launches the pump test before returning to normal operating mode.

Refer to [Pump Test](#) for additional information.





Initialize

The **Initialize** option is used to restore the original factory default settings of the detector.

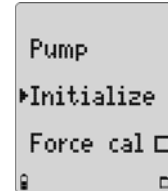
Press  to scroll to **Initialize** and press  within 20 seconds to confirm.



From the **Initialize?** screen, within 5 seconds press  **No** to exit or press  **Yes** to initialize.

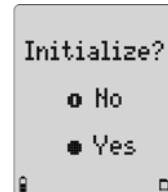

If **No** is selected, the following screen displays and the detector exits the initialize option.

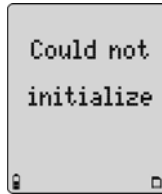

If **Yes** is selected, the following screen displays while performing the initializing process.

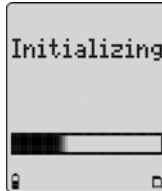

When initializing is complete, the following screen displays.

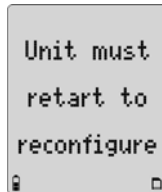

The detector deactivates and then immediately reactivates. The detector then performs the self-test while it reconfigures to the default settings.

Verify all settings and alarm setpoints, and then calibrate the sensors.

Force Calibration

The **Force cal** option is used to force the detector to enter calibration if a sensor is overdue upon start-up. Press \blacktriangledown to scroll to **Force cal**.

Press \bigcirc to toggle between enable/disable.

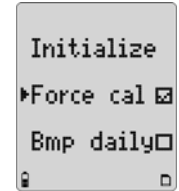

The detector is shipped with the **Force cal** option disabled.

Bump Daily

The **Bmp daily** option is used to force the detector to perform a daily bump check to ensure that it is responding to the test gas.

Press \blacktriangledown to scroll to **Bmp daily**. Press \bigcirc to toggle between enable/disable.

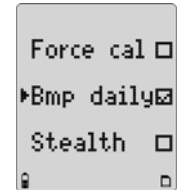

The detector is shipped with the **Bmp daily** option disabled.



Oxygen and LEL Sensors: Daily bumps are required whenever the detector has been reactivated following 00:00 hours (midnight).

Stealth Mode

Note

The **Stealth** and **IR Stlth** options cannot be enabled simultaneously.

The **Stealth** option is used to disable the backlight, visual alarms, and audible alarms when concealment is required. Only the vibrator and the LCD activate during an alarm condition.

Press  to scroll to **Stealth**. Press  to toggle between enable/disable.

The detector is shipped with the **Stealth** option disabled.

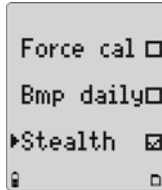



IR Stealth Mode (Optional)

This is an optional feature and must be factory ordered.

Note

The **Stealth** and **IR Stlth** options cannot be enabled simultaneously.

The **IR Stlth** option operates the same as the **Stealth** option except that it activates infrared LEDs that are located in the right alarm bar. If this option is included on the detector, press  to scroll to **IR Stlth**. Press  to toggle between enable/disable.



The detector is shipped with the **IR Stlth** option disabled.

Alarms

The following table describes the detector alarms and corresponding screens.

During an alarm condition, the detector activates the backlight and displays the current ambient gas reading.

If more than one type or level of alarm exists simultaneously, a multi-gas alarm will result.

To change the factory-set alarm setpoints, refer to [Calibration and Setting Alarm Setpoints](#).

Table 6. Alarms



Alarms	Display	Alarms	Display
<p>Low Alarm:</p> <ul style="list-style-type: none"> • Fast beep • Slow flash • ALARM and target gas bar flash • Vibrator alarm activates 		<p>High Alarm:</p> <ul style="list-style-type: none"> • Constant beep • Fast flash • ALARM and target gas bar flash • Vibrator alarm activates 	
<p>STEL Alarm:</p> <ul style="list-style-type: none"> • Constant beep • Fast flash • ALARM and target gas bar flash • Vibrator alarm activates 		<p>TWA Alarm:</p> <ul style="list-style-type: none"> • Fast beep • Slow flash • ALARM and target gas bar flash • Vibrator alarm activates 	

Table 6. Alarms (cont.)

Alarms	Display	Alarms	Display
<p>Multi-Gas Alarm:</p> <ul style="list-style-type: none"> Alternating low and high alarm beep and flash ALARM and target gas bars flash Vibrator alarm activates 	<p>The display shows 'LOW ALARM TWA' at the top. Below it, 'SO2' is followed by '0'. In the middle, there are two bars: one for '10' and one for '35'. At the bottom, '20.9' is shown with a bar, and '0' is shown with a bar.</p>	<p>Over Range Alarm: (Over Level Exposure)</p> <ul style="list-style-type: none"> Fast beep and flash ALARM and target gas bar flash Vibrator alarm activates 	<p>The display shows 'HIGH ALARM' at the top. Below it, 'SO2' is followed by '0'. In the middle, there are two bars: one for '0' and one for '0'. At the bottom, '20.9' is shown with a bar, and '0L' is shown with a bar.</p>
<p>Sensor Alarm:</p> <ul style="list-style-type: none"> One beep every 15 seconds FAIL flashes above the failed sensor 	<p>The display shows 'SO2' followed by '0'. Below it, there are two bars: one for '0' and one for '0'. At the bottom, '20.9' is shown with a bar, and 'FAIL' is shown with a bar.</p>	<p>Automatic Shutdown Alarm:</p> <ul style="list-style-type: none"> Eight beeps and flashes LOW displays Vibrator alarm temporarily activates 	<p>The display shows 'Battery depleted.' and 'Turning off' in two lines.</p>
<p>Low Battery Alarm:</p> <ul style="list-style-type: none"> One beep and two flashes every 25 seconds LOW flashes 	<p>The display shows 'SO2' followed by '0'. Below it, there are two bars: one for '0' and one for '0'. At the bottom, '20.9' is shown with a bar, and 'LOW' is shown with a bar.</p>	<p>Normal Shutdown:</p> <ul style="list-style-type: none"> Three beeps and flashes 	<p>The display shows 'Turning off in:' and '3...' in two lines.</p>

Table 6. Alarms (cont.)

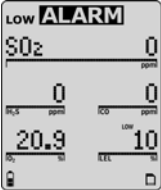
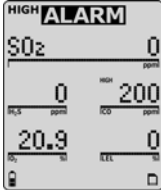
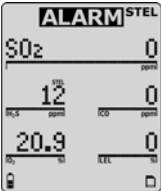
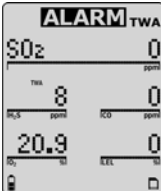
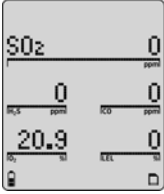
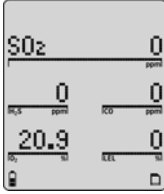
Alarms	Display	Alarms	Display
<p>Confidence Beep:</p> <ul style="list-style-type: none"> Two fast beeps every 10 seconds 		<p>MMC Fail Alarm:</p> <ul style="list-style-type: none"> One beep every 5 seconds □ flashes 	
Alarms		Displays	
<p>Pump Alarm:</p> <ul style="list-style-type: none"> Two fast beeps and alternating flashes Vibrator alarm activates ALARM and ✳ flash 			

Note

If the latched alarm function is activated, the audible and visual alarms continue to beep and flash until the alarm condition is acknowledged. To acknowledge a latched alarm, press ○. The alarms cannot be deactivated if an alarm condition exists.

If the stealth option is enabled, the detector only vibrates during an alarm; the audible and visual alarms are disabled.

Gas Exposures Computed

⚠ Warning

To avoid possible personal injury, do not deactivate the detector during a work shift. TWA and STEL readings reset if the detector is deactivated for more than 5 minutes.

Table 7. Computed Gas Exposures

Gas Exposure	Description
TWA (toxic only)	Time-weighted average (TWA) based on accumulated exposure to toxic gases averaged over a work day according to OSHA or ACGIH method.
STEL (toxic only)	Short-term exposure limit (STEL) to gas based on a 5-15 minute user selectable period.
Maximum* (peak)	Maximum (MAX) concentration encountered during work shift.

*For oxygen, it is the highest or the lowest concentration encountered.

Viewing Gas Exposures

Press and hold  until the MAX gas exposures screen displays.

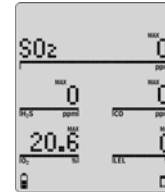

The TWA gas exposures display next.

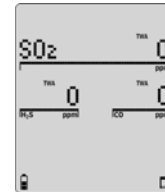

Lastly, the STEL gas exposures display.

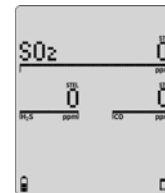

Clearing Gas Exposures

The exposures automatically clear after 5 minutes of the detector being deactivated.

To clear the MAX, TWA, and STEL exposure readings immediately, press and hold ○ and ▲ simultaneously. The detector displays the following screen during the countdown.

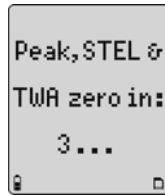

Note

Hold ○ and ▲ for the entire countdown, otherwise the MAX, TWA, and STEL exposure readings will not clear.

Gas Alarm Setpoints

The gas alarm setpoints trigger the gas alarms and are described in Table 8.

Table 8. Gas Alarm Setpoints

Alarm	Condition
Low alarm	<i>Toxics and combustibles:</i> Ambient gas level above low alarm setpoint. <i>Oxygen:</i> Ambient gas level may be set above or below 20.9%.
High alarm	<i>Toxics and combustibles:</i> Ambient gas level above high alarm setpoint. <i>Oxygen:</i> Ambient gas level may be set above or below 20.9%.
TWA alarm	<i>Toxic only:</i> Accumulated value above the TWA alarm setpoint.
STEL alarm	<i>Toxic only:</i> Accumulated value above the STEL alarm setpoint.
Downscale alarm	<i>Toxic:</i> If sensor reading is negative (half of the TWA setpoint). <i>LEL:</i> If sensor reading is negative (half of the low alarm setpoint).
Multi-gas alarm	Two or more gas alarm conditions.

Viewing the Alarm Setpoints

To view the current alarm setpoints for all of the sensors, press ▲ during normal operation.

The TWA, STEL, low, and high alarm setpoint screens display in the following order:

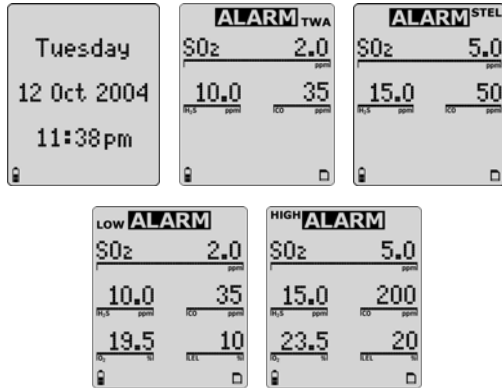

If a correction factor has been applied to a sensor, one of the following screens display indicating the sensor and gas type.

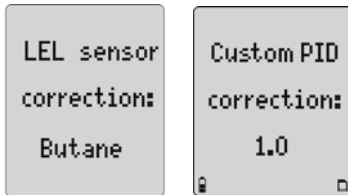

Resetting Gas Alarm Setpoints

Note

Standard factory alarm setpoints vary by region.

The following table lists the factory alarm setpoints according to the Occupational Safety and Health Association (OSHA) settings.

Table 9. OSHA Sample Factory Alarm Setpoints

Gas	TWA	STEL	Low	High
O ₂	N/A	N/A	19.5% vol.	23.5% vol.
LEL	N/A	N/A	10% LEL	20% LEL
CO	35 ppm	50 ppm	35 ppm	200 ppm
H ₂ S	10 ppm	15 ppm	10 ppm	15 ppm
PH ₃	0.3 ppm	1.0 ppm	0.3 ppm	1.0 ppm
SO ₂	2 ppm	5 ppm	2 ppm	5 ppm
Cl ₂	0.5 ppm	1.0 ppm	0.5 ppm	1.0 ppm
NH ₃	25 ppm	35 ppm	25 ppm	50 ppm
NO ₂	2.0 ppm	5.0 ppm	2.0 ppm	5.0 ppm
HCN	4.7 ppm	10.0 ppm	4.7 ppm	10.0 ppm
ClO ₂	0.1 ppm	0.3 ppm	0.1 ppm	0.3 ppm
O ₃	0.1 ppm	0.1 ppm	0.1 ppm	0.1 ppm
VOC	50 ppm	100 ppm	50 ppm	100 ppm

To change the factory-set alarm setpoints, refer to [Calibration and Setting Alarm Setpoints](#).

Note

To disable an alarm, set the alarm setpoint to 0 (zero).

Stopping a Gas Alarm

The low and high alarms stop when the ambient gas level returns to below the low alarm setpoint.

Note

If alarms are set to latch, press to reset the alarms.

The TWA and STEL alarms can be stopped either by

- clearing the MAX, TWA, and STEL peak exposures (refer to [Clearing Gas Exposures](#)), or
- deactivating the detector for 5 minutes (minimum) and then reactivating it again.

Sensor Alarm

The detector tests for missing or defective sensors during the activation self-test. If a sensor fails the self-test, the detector displays **FAIL** above the failed sensor. Refer to [Troubleshooting](#).

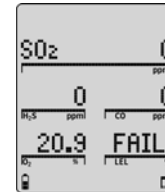

Pump Alarm

The external pump draws air over the sensors continually. If the pump stops operating or becomes blocked, the detector activates the pump alarm. The following screens display.

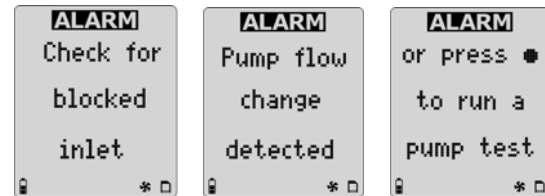

The pump alarm continues until the blockage is cleared or it is acknowledged by pressing . If is pressed, the detector automatically launches a pump test to reset the pump module.

Refer to [Pump Test](#) for more information. If the pump test is successful, the detector returns to normal operation, otherwise the pump alarm continues.

Low Battery Alarm

The detector tests the batteries upon activation and continuously thereafter. Battery power is continually displayed during normal operation. If the battery voltage is low, the detector activates the low battery alarm.

The low battery alarm continues until the batteries are replaced/charged, or until the battery power is almost depleted. If the battery voltage becomes too low, the detector deactivates.

Note

Typically, the low battery alarm continues for 30 minutes before the detector automatically deactivates.

Automatic Shutdown Alarm

If the battery voltage is in immediate danger of falling below the minimum operating voltage, the audible alarm beeps eight times and the visual alarm flashes eight times. After 3 seconds, the LCD deactivates and the detector exits normal operation.

To replace or charge the batteries, refer to [Replacing/Charging the Batteries](#).

Calibration and Setting Alarm Setpoints

Guidelines

When calibrating the detector, adhere to the following guidelines:

- Recommended gas mixture:
 - CO: 50 to 500 ppm balance N₂
 - H₂S: 10 to 100 ppm balance N₂
 - PH₃: 1 to 5 ppm balance N₂
 - SO₂: 10 to 50 ppm balance N₂
 - Cl₂: 3 to 25 ppm balance N₂
 - NH₃: 20 to 100 ppm balance N₂
 - NO₂: 5 to 50 ppm balance N₂
 - HCN: 5 to 20 ppm balance N₂
 - ClO₂: 0.1 to 1.0 ppm balance N₂
 - O₃: 0.1 to 1.0 ppm balance N₂
 - VOC: 100 ppm isobutylene
 - LEL: 10 to 100% LEL or 0.5 to 5% by vol. methane balance air
 - O₂: clean air, 20.9 %
- CG-Q58-4 and CG-Q34-4 calibration gas (4-gas mix) are available from BW Technologies. See the section, [Replacement Parts and Accessories](#).

- Calibration accuracy is never better than the calibration gas accuracy. BW Technologies recommends a premium-grade calibration gas. Gases with National Institute of Standards and Technology (NIST) traceable accuracy improves the validity of the calibration. Do not use a gas cylinder beyond its expiration date.
- Calibrate a new sensor before use. Install the sensor, activate the detector, and allow the sensor to stabilize before starting calibration.
Used sensor: 60 seconds
New sensor: 5 minutes
- Calibrate the detector at least once every 180 days (calibrate HCN detectors at least once every 90 days) depending upon use and sensor exposure to poisons and contaminants.
- Calibrate the detector if the ambient gas varies during start-up.
- Calibrate the sensor before changing the alarm setpoints.
- Calibrate only in a clean atmosphere that is free of background gas.
- To disable an alarm, set the alarm setpoint to **0** (zero).

- If the **Auto cal** option is enabled, the oxygen (O₂) sensor calibrates automatically every time the detector is activated. Activate the detector in a normal (20.9% oxygen) atmosphere.
- After activating the detector, allow it to stabilize for 1 minute before performing a calibration or bump test.
- If a certified calibration is required, contact [BW Technologies](#).

Note

A generator must be used for O₃ and ClO₂ sensors.

Diagnostics Protection

The detector tests the ambient air (auto zero) and the test gas that is applied (auto span) to ensure it meets expected values.

Auto zero sets the zero-gas level of the sensor. If ambient gas is present, the zero level will be incorrect.

If excessive gas is present, the detector displays an error message and lists the affected sensor.

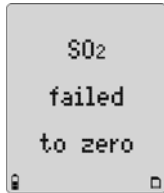

In auto span, if target gas is not detected or does not meet expected values, a message displays that the detector is exiting calibration mode. The detector retains the previous set values.

Applying Gas to the Sensors

The calibration cap and hose are shipped with the detector. Refer to Table 10 and Figure 3 for installation.

Note

The calibration cap can only be used during the calibration span process.

Table 10. Applying Gas to the Sensors

Item	Description
1	Detector and calibration cap
2	Calibration hose
3	Regulator and gas cylinder

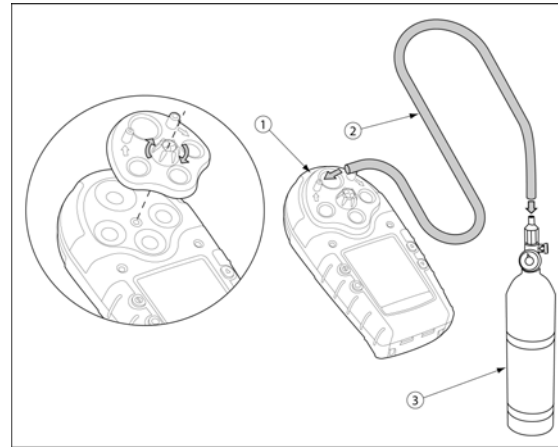

Figure 3. Applying Gas to the Sensors

Calibration Procedure

To calibrate the detector and set the alarm setpoints, perform the following procedures.

Note



To bypass a step during the calibration process (after auto zero), press \odot . Calibrate O₂ in clean air.

Start Calibration

Note

Verify that the calibration gas being used matches the span concentration value(s) that are set for the detector. Refer to [Span Gas Value](#).

Correction factors are not applied during calibration. Correction factors that were set prior to calibration are restored when the detector returns to normal operation.

1. To enter calibration, in a clean atmosphere press and hold  and  simultaneously as the detector beeps, flashes, and vibrates to the corresponding countdown.

The following screen displays to indicate that calibration mode has been entered.

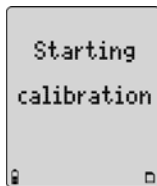

Auto Zero and Oxygen (O₂) Sensor Calibration

2. **AUTO-ZERO** flashes while the detector automatically zeroes the toxic and combustible sensors, and calibrates the O₂ sensor.

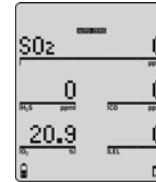

Note

Do not apply calibration gas during this process, otherwise the auto zero step will fail.

Passcode Protect Activated (Optional)

When auto zero is complete and if the passcode protect option is enabled, the detector prompts for the passcode.

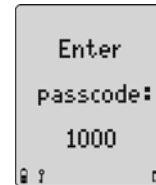

GasAlertMicro 5 and GasAlertMicro 5 PID

User Manual

The passcode must be entered to proceed. If required, refer to [Passcode Protect](#) in User Options menu.

3. Press \blacktriangle or \blacktriangledown to scroll to the correct passcode. When it displays, press \bigcirc within 5 seconds to confirm. If the correct passcode is entered, the detector beeps twice and proceeds to the auto span.

Incorrect Passcode: If the passcode is incorrect or is not confirmed within 5 seconds by pressing \bigcirc , the following screens display.

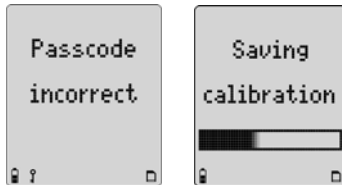

The detector saves the calibration and returns to normal operation.

Auto Span

After auto zero and the correct passcode is entered (if required), the following three screens display.

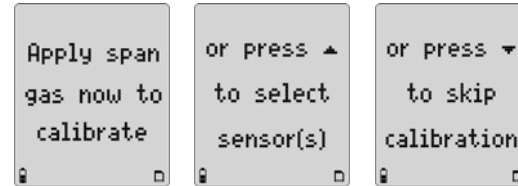

Note

Span sensors in the following order:

- Exotics (NH_3 , ClO_2 , O_3 , and Cl_2)
- Single gas
- Quad gas (H_2S , CO , LEL , and O_2)
- PID

Apply Span Gas Now

Note

A generator must be used for O₃ and ClO₂ sensors.

- **ClO₂:** BW recommends that a Tedlar bag be used as a buffer between the generator and the detector (while using the calibration cap) to regulate the flow rate to ensure accurate readings.
- Set the generator to 0.5 ppm at a flow rate of 0.5 l/min. (liter per minute).
- Allow the Tedlar bag to fill for several minutes before initiating calibration.
- **O₃:** Calibrate only using the calibration cap. Do not use a Tedlar bag.

Depending upon the gas cylinder being used, one or all four sensors can be calibrated at one time.

- 4a. Attach the calibration cap and apply gas to the sensor(s) at a flow rate of 500 ml/min. (1000 ml/min. for NH₃ and Cl₂). Refer to Figure 3. Applying Gas to Sensors.

☐ flashes as the detector initially detects the calibration gas.

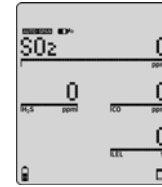

After 30 seconds the detector beeps and ☐ stops flashing. **AUTO-SPAN** flashes while spanning the sensors until the detector has attained a sufficient level of the expected gas.

Refer to Table 11 for times required to span.

Table 11. Time Required to Span

Gas Type	Time Required to Span
Most toxic gases	2 minutes
Exotic toxic gases	5 minutes
LEL (combustibles)	30 seconds
PID gases	2 minutes

Insufficient Level: If a sensor does not attain a sufficient level of expected gas, it is cleared from the LCD and is not spanned.

While the detector is spanning the sensor(s), a countdown of time remaining displays in the lower left of the screen.

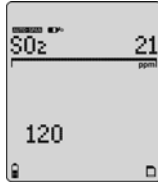

When the span is complete, the following screen displays.

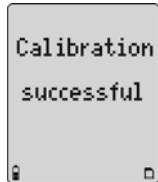

Proceed to [Successful Span](#) step #5. If problems occur during the span, refer to [Unsuccessful Span](#) for possible solutions.

Select Sensor

4b. If is pressed to select **Sensor**, the following screen displays. The list of sensors will vary, depending upon the sensors that are installed.

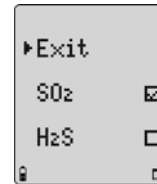

Note

Only sensors that are selected are accepted for the current span.

Ensure that the checkbox is enabled for the sensor that is to be spanned.

Press to exit. The **Apply span gas to calibrate** screen then displays. Refer to back to step #4a.

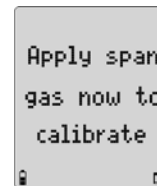

Skip Calibration

4c) If Ⓢ is pressed, proceed to step #6.

Successful Span

If the sensor(s) has spanned successfully, the audible alarm beeps three times and the following screens display.

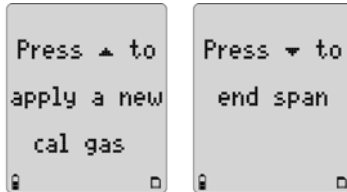

5. If there are more sensors to span, remove the existing calibration gas cylinder and connect the next cylinder.

Press ▲ and apply gas to span the other sensor(s).

Or

Press ▼ to end the span and proceed to step #6 to set the calibration due dates.

If all of the sensors have successfully spanned, the following screen displays prior to continuing with the calibration process.



Unsuccessful Span

If the sensor(s) did not span successfully, refer to the following sections for possible solutions:

- [Failed Span](#)
- [No Gas Detected](#)
- [Did Not Reach Target Span](#)
- [Large Span](#)

Failed Span

If a sensor fails the span, the following error message displays.

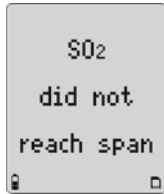

If the sensor is not recalibrated, the sensor displays as **FAIL** in normal operation the next time the detector is activated.

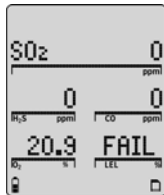

If all of the sensors fail the span, the following screen displays.

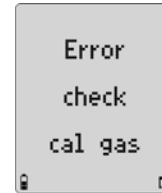

Press  to exit and then restart calibration in an atmosphere that is clear of the targeted gases. If the span fails a second time, restart the detector to test the sensors.

If all of the sensors fail the span, the due dates for calibration cannot be set.

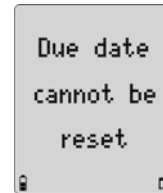

If the detector fails to span the sensors, confirm the following:

- Ensure gas is being applied to the sensor.
- Ensure the sensors detect at least one-half of the expected gas concentration in the first 30 seconds.
- Ensure the gas concentration does not drop below one-half of the expected gas level during the span.

If the detector still fails to span the sensor(s), repeat the calibration using a new gas cylinder.

If the span is still unsuccessful, replace the sensor(s). Refer to [Replacing a Sensor or Sensor Filter](#).

No Gas Detected

If the detector does not detect any gas within 30 seconds, the following screens display.



Press ▲ to reapply gas using another gas cylinder, or press ▼ to end the span and proceed to step #6.

Did Not Reach Target Span

If the span did not reach the target span as set in the user options menu ([Span Gas Value](#)) for the selected sensor, the detector displays the following screens.

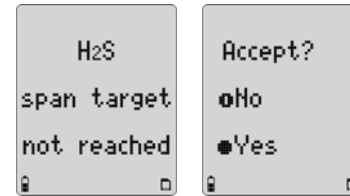

Not reaching the target span can be the result of

- a problem with the span gas,
- the gas cylinder being past the expiry date, or
- a problem with the sensor.

Accept Current Span: If the span gas, gas cylinder, and sensor appear to be correct, press ○ to accept the current span.

Reject Current Span: Press ⊙ to reject. Verify the span gas and the detector settings, and then recalibrate the sensor.

Large Span

If the span adjustment is unusually large (more than 15%), the following screens display.

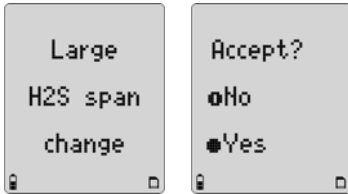

Ensure the calibration gas cylinder being used is correct and that the span concentration value(s) (refer to [Span Gas Value](#)) of the detector matches the value(s) of the gas cylinder.

Adjustment Expected: If the calibration adjustment is expected, press to accept the span.

Adjustment Not Expected: If the calibration adjustment is not expected or the span gas value does not match the calibration gas cylinder, press to reject the span and calibrate that sensor again.

Setting the Calibration Due Date

When the span is complete, the calibration due date can be set for each sensor that has spanned successfully.

The following screen displays.

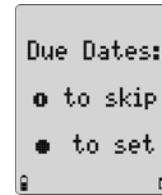

6. Press to set the calibration due dates. The following screens display.

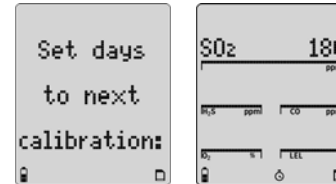

Note

Unless a new due date value is entered, the detector automatically resets to the previously entered number of days (eg. 180) for each sensor that has spanned successfully.

Or

Press to bypass and proceed to step #9.

The calibration due dates are set in the following order:

- Toxic 1
- Toxic 2 (H₂S and CO)
- LEL
- O₂

If an attempt is made to change the due date of a unsuccessfully spanned sensor, the following screens display.

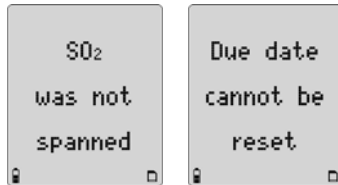

The detector then automatically proceeds to the next sensor.

7. To change the calibration due date (1-365 days), press \blacktriangledown or \blacktriangle until the new value displays. Press \bigcirc within 5 seconds to confirm.

Or

Press $\textcircled{\text{O}}$ to bypass a sensor and proceed to the next sensor.

The detector automatically proceeds to the next sensor to set the calibration due date.

Note

If a value is changed but \bigcirc is not pressed within 5 seconds to confirm, the following screen displays.

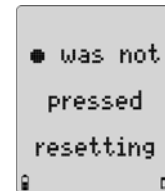

The previous value is automatically retained. The detector proceeds to the next sensor calibration due date.

- Repeat step #7 to set the calibration due date for the remaining sensors.
- Press to set the alarm setpoints and proceed to the following section [Alarm Setpoints](#).

Or

Press to bypass setting the alarm setpoints and proceed to [Finish Calibration](#).

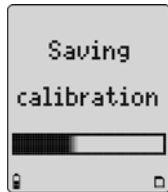

Alarm Setpoints

Factory alarm setpoints may vary by region. Refer to [Resetting Gas Alarm Setpoints](#) for an example. Alarms can be set to any value within the detection range of the selected sensor. Refer to [Specifications](#).

Note

To disable an alarm setpoint, set it to 0 (zero).

When setting alarm setpoints, if the new setpoint is not confirmed within 5 seconds by pressing , the following screen displays.

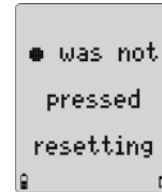

The previous setpoint is retained and the detector proceeds to the next setpoint.

The setpoints are set in the following order:

- TWA (if applicable)
- STEL (if applicable)
- low
- high

To bypass a setpoint, press to save the current value and proceed to the next setpoint.

Setting the TWA Alarm Setpoint

The current TWA alarm setpoint displays for the selected sensor (if applicable).

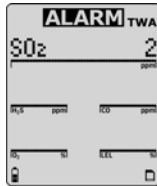

10. Press \blacktriangledown or \blacktriangle to change the value for the TWA alarm setpoint. When the required value displays, press \bigcirc to confirm.

Setting the STEL Alarm Setpoint

The current STEL alarm setpoint displays for the selected sensor (if applicable).

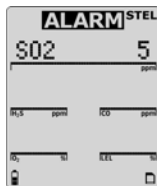

11. Press \blacktriangledown or \blacktriangle to change the value for the STEL alarm setpoint. When the required value displays, press \bigcirc to confirm.

Setting the Low Alarm Setpoint

The current low alarm setpoint displays for the selected sensor.

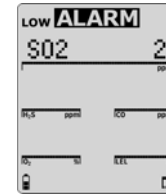

12. Press \blacktriangledown or \blacktriangle to change the value for the low alarm setpoint. When the required value displays, press \bigcirc to confirm.

Setting the High Alarm Setpoint

The current high alarm setpoint displays for the selected sensor.

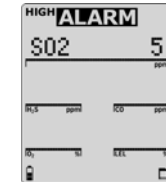

13. Press \blacktriangledown or \blacktriangle to change the value for the high alarm setpoint. When the required value displays, press \bigcirc to confirm.

Setting the Remaining Alarm Setpoints

14. Repeat steps #10-13 to set alarm setpoints for the remaining sensors. The audible alarm beeps four times when the alarm setpoint function is complete.

When the due dates have been set for all required sensors, the detector emits two quick beeps and then proceeds to the gas alarms setpoints screen.

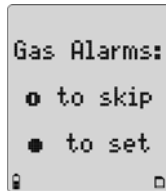

Finish Calibration

The detector displays the following to indicate that the calibration process is complete.

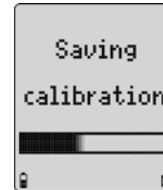

The detector then returns to normal operation.

Verification

After calibration is complete and the detector is in normal operating mode, test it using a gas cylinder other than the one used for calibration. The gas concentration should not exceed the sensor's detection range. Confirm that the LCD displays the expected concentration values.

To ensure that the reading are accurate, apply the test gas for the same amount of time as was applied to the sensor when it was calibrated.

Example: SO₂ span time 2 minutes therefore, apply test gas for 2 minutes.

Attaching the Accessories

Installing the Pump Module

The BW motorized pump module is an optional accessory for the detector. The pump module is designed to be used with the sample probe to test for gases in confined spaces.

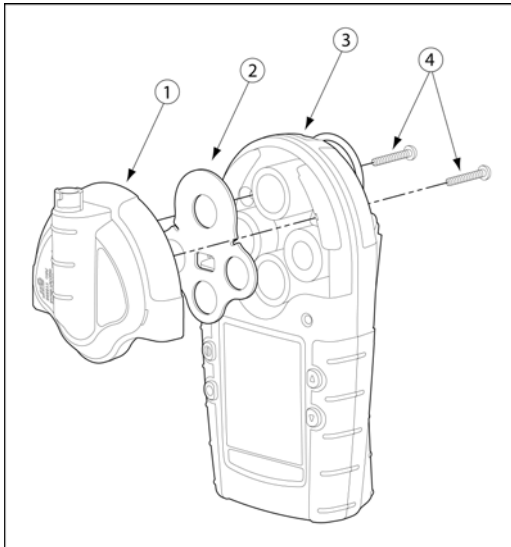

Figure 4. Installing the Pump Module

Table 12. Installing the Pump Module

Item	Description
1	Motorized pump module
2	Sensor filter
3	Detector
4	Machine screws (2)

1. To install the pump module, deactivate the detector.
2. Remove the two machine screws and the sensor cover. Remove the sensor filter from the sensor cover and insert it into the pump module.
3. Attach the pump module to the detector and replace the two machine screws.
4. Activate the detector. The detector performs the start-up self-tests and the pump test. Refer to [Pump Test](#).
5. If the pump has been purchased separately (not included with the detector), the pump flow rate must be set prior to using the pump. Refer to [Pump](#) in the [Tech Mode](#) section.

Note

Do not exchange pump modules between detectors.

Attaching the Sample Probe

The sample probe is used to safely test for gas in confined spaces before entering.

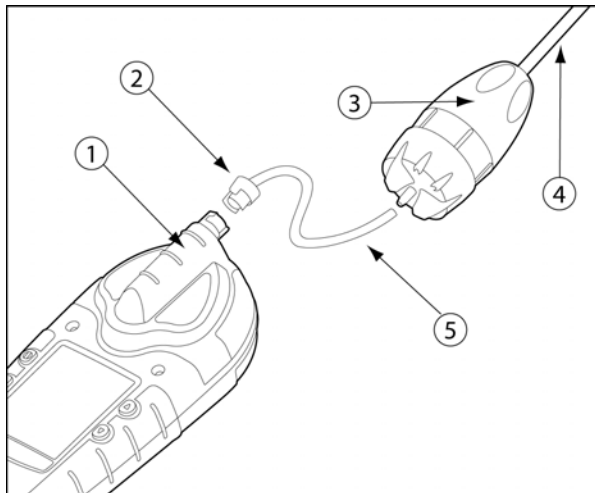

Figure 5. Attaching the Sample Probe

Table 13. Attaching the Sample Probe

Item	Description
1	Motorized pump module
2	Connector
3	Sample probe
4	Sample probe 10 in. tubing (custom lengths can be ordered)
5	Flexible connector hose

⚠ Warning

The sample probe must be used with the pump module only. Ensure that all connections are secure before sampling.

1. Make all of the required connections as illustrated in Figure 5 Attaching the Sample Probe.
2. Activate the detector.

⚠ Warning

If the length of the tubing is 50 ft. or longer, the Fast Pump option must be enabled prior to sampling. Refer to [Fast Pump](#) in user options.

3. Insert the sample probe tubing into the confined space.

Depending upon the length of the tubing and the type of gas in the confined space, allow a minimum of 3 seconds per ft. of hose to ensure the readings stabilize before entering the area.

Example: 50 ft. = 2.5 minutes

Datalogger

Detectors that are equipped with the datalogger option record information that can be compiled to create a report.

Datalog

Datalog information is recorded based on the sampling rate that is set in the **Logger** option. The detector can be set to record a datalog sample once every 1 to 127 seconds.

To set the sample rate, refer to [Logger Option](#) in the user options.

The following information is recorded in a datalog:

- Date and time
- Serial number of the detector
- Type of gas the detector monitors
- Gas reading(s) that display
- STEL and TWA readings
- Sensor status
- Detector status
- Passcode protect enabled/disabled
- STEL period setting
- Confidence beep enabled/disabled
- Automatic backlight enabled/disabled
- Stealth mode is enabled/disabled
- Latching alarm enabled/disabled
- Calibration past due user option enabled/disabled
- Language the detector is set to display

MultiMediaCard (MMC) Compatibility

An Infineon 32 MB MMC Flash Memory card is supplied with the detector.

⚠ Caution

To ensure the Intrinsic Safety rating of the detector, use only the 32 MB Infineon MMC.

To purchase additional Infineon 32 MB MMCs, refer to [Replacement Parts and Accessories](#).

Inserting the MMC/SD Card

To insert the MultiMediaCard/Secure Digital card (MMC/SD) into the detector, refer to Table 14, Figure 6, and the following procedures.

Table 14. Removing the MMC/SD Card

Item	Description
1	Back of detector
2	Battery pack
3	MMC/SD card

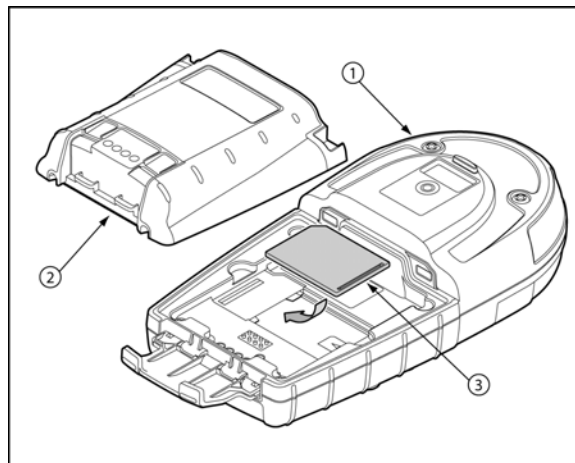
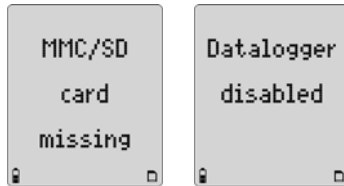

Figure 6. Installing and Removing the MMC/SD

1. Deactivate the detector.
2. Release the latch and remove the battery pack. If required, refer to Figure 3.
3. Insert the MMC/SD pins face down.
4. Replace the battery pack and secure the latch.

MMC/SD Troubleshooting

The MMC or secure digital (SD) card is not required for operation in detectors equipped with datalogging. However, the following two screens display if the card is not inserted.



A new MMC is automatically formatted when it is inserted in the detector. When the detector is activated, it begins the self-test and then displays the following screen.



Restoring Datalog Files

If the MMC has been accidentally reformatted or erased by the computer application, the following screens display when the card is inserted into the detector.



⚠ Warning

Only erased data files can be restored using the detector. Computer applications sometimes write data over erased files and that data cannot be restored by the detector.

Always create back up files on the computer.

To restore the logfile, complete the following:

1. From the detector, press  to restore the log file. The following screen displays.



If the detector successfully restores the log file, the following screen displays and the start-up tests continue.

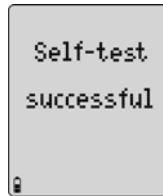

- Using the computer, verify that the logfile has been restored. When the normal operating screen displays, deactivate the detector.
- Remove the MMC and insert it into the card reader.
- From the computer desktop, double-click **My Computer** to view the list of drives.
- Double-click the **Removable Disk** drive to access **LOGFILE0.CSV**. Open the log file and verify that the data has been restored.
- After verifying that the log file has been restored, re-insert the MMC into the detector.

If **LOGFILE0.CSV** does not display, ensure that the MMC is installed in the card reader correctly and that all connections are secure.

Reformatting the MMC

To reformat the MMC, complete the following:

- Insert the MMC into the card reader.
- From the computer desktop, double-click **My Computer** to view the list of drives.
- Double-click the **Removable Disk** drive to access **LOGFILE0**.
- Select **LOGFILE0** and delete.
- Reinsert the MMC into the detector.
- Activate the detector. The start-up self-test begins and the following screens display.

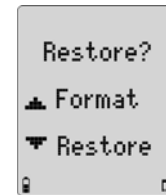
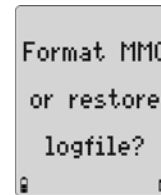
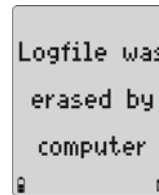

7. Press  to format the MMC. The following screen displays.

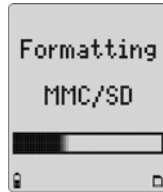

For any additional MMC/SD errors, refer to [Troubleshooting](#).

Import Datalogs to FleetManager

Note

Refer to the following minimum requirements before importing datalogs to FleetManager.

Minimum PC Requirements

- 500 MHz Pentium (or equivalent)
- 100 MB free hard disk space
- Microsoft® Windows 98 or later
- USB port

Using MicroDock II to Import to FleetManager

Note

If the detector is used with the MicroDock II Automatic Test and Calibration Station to import datalogs to FleetManager, refer to the MicroDock II User Manual for complete instructions.

Using a Card Reader to Import to FleetManager

To import a datalog file from the detector to FleetManager, complete the following:

1. Deactivate the detector.
2. Release the latch and remove the battery pack.
3. Remove the MMC/SD from the detector. Refer to Figure 6 and Table 14.
4. Connect the card reader to the USB port on the computer.
5. Insert the MMC into the card reader (ensure that the pins face down).

6. From the computer desktop, click **FleetManager**. A popup displays. Select one of the following:
 - **Create New Database**
 - **Use Existing Database**
7. Another window opens. Select the required database.
8. From the FleetManager window, click **Import** from the left menu bar.
9. A popup displays: **No MicroDock devices found**. Click **OK**.

A browser window opens **Key in Data Log File Path**. If required, expand the window.

10. Press to browse to **My Computer**.
11. From **My Computer**, select **Removable Disk** drive.
12. From the **Removable Disk** drive, double-click **LOGFILE0**.

For additional information and procedures, refer to the Fleet Manager Deluxe CD and FleetManager on-line help.

View Datalog Files in Spreadsheets

The datalog files can be loaded from the MMC/SD into most spreadsheet applications using a card reader. Compatible software applications are

- Microsoft® Excel 98 or later,
- Quattro Pro,
- Lotus 1-2-3,
- Microsoft® Access, and
- Microsoft® Word.

To view a datalog file in a software spreadsheet, complete the following:

1. Deactivate the detector and remove the MMC/SD (refer to Figure 6).
2. Insert the MMC/SD into the card reader.
3. From the computer desktop, double-click **My Computer** to view the list of drives.
4. Double-click **Removable Disk** drive.
5. Double-click **LOGFILE0**.

Refer to the following three tables for a spreadsheet example and definitions.

Example of a Datalog Spreadsheet

When datalog information is imported into most spreadsheet software, it appears similar to the example below.

Note: Not all columns are included in this example. Additional Toxic TWA and Toxic STEL display on a normal spreadsheet.

⚠ Warning: Some compatible software packages have an internal file size limit of and may not load the entire file. Check the software limit.

Table 15. Datalog Spreadsheet Example

Date dd-mm- yy	Day Mon=1	Time hh:mm:ss	Toxic1 ppm	Toxic2 ppm	Toxic3 ppm	LEL %CH4 %LEL	O ₂ %	Toxic 1 TWA ppm	Toxic 1 STEL ppm	Status Codes	Serial Number	Unit Config
23-12-05	#4	9:54:25	5	10	35			--	--	33-----	S104-000001	
23-12-05	#4	9:54:30	10	15	50			--	--	44-----	S104-000001	
23-12-05	#4	9:54:35	5	10	35	10	19.5	--	--	1111----	S104-000001	
23-12-05	#4	9:54:40	10	15	200	20	23.5	--	--	2222----	S104-000001	
23-12-05	#4	9:54:45	0	0	0	24	20.9	--	--	-D-E---D	S104-000001	FCEKNL
23-12-05	#4	9:54:50	0	0	0	24	20.9	0	0	-----	S104-000001	FCEKNL
23-12-05	#4	9:54:55	0	0	0	24	20.9	0	0	--L----L	S104-000001	FCEKNL
23-12-05	#4	9:55:00	0	0	0	24	20.9	0	0	LLH---M	S104-000001	FCEKNL
23-12-05	#4	9:55:05	5	10	35			0	0	LLH---M	S104-000001	
23-12-05	#4	9:55:10	10	15	50			0	0	LLL---M	S104-000001	
23-12-05	#4	9:55:15	5	10	35	10	19.5	0	0	-L----L	S104-000001	
23-12-05	#4	9:55:20	10	15	200	20	23.5	0	0	-----	S104-000001	
23-12-05	#4	9:55:25	0	0	0	24	20.9	0	0	-----B-	S104-000001	FCEKNL
23-12-05	#4	9:55:30	0	0	0	24	20.9	0	0	-----B-	S104-000001	FCEKNL

Table 16. Datalog Status Codes

Status Codes					
—	Normal operation	G	Backlight is on		
L	Low alarm	v	STEL and high alarm (dual alarms)	1	Alarm setpoint 1 (low alarm)
H	High alarm	w	TWA and STEL alarm (dual alarms)	2	Alarm setpoint 2 (high alarm)
T	TWA alarm	x	TWA, STEL, and low (triple alarms)	3	Alarm setpoint 3 (TWA alarm)
U	TWA and low alarm (dual alarms)	y	TWA, STEL, and high (triple alarms)	4	Alarm setpoint 4 (STEL alarm)
V	TWA and high alarm (dual alarms)	O	Overload / sensor is over-ranged	D	Calibration due date (days)
s	STEL alarm	C	Calibrating	E	Elapsed / last calibration (days)
u	STEL and low alarm (dual alarms)	F	Failure - sensor failure	Z	Auto zeroing
f	Fresh air delay	I	Time set	t	testing
Pump Codes					
P	Plugged (blocked) - pump alarm	F	Failure / pump failure		
Battery Status Codes					
—	Batteries OK	B	Low battery alarm	C	Confidence beep is active
Alarm Status Codes					
L	Low alarm	M	Multi-gas alarm	S	Automatic shutdown
H	High alarm	C	Calibration	F	Failure / self-test fail
T	TWA alarm	Q	Off/quit / manual shutdown	R	RTCC / real-time clock failure

Note: TWA readings greater than 99 are recorded as OL.

Table 17. Datalog Gas and Correction Factor Sensor Codes

Gas Sensor Codes									
A	No sensor	B	H ₂ S	C	H ₂ S COSH	D	CO	E	CO COSH
F	SO ₂	G	PH ₃	H	NO ₂	I	HCN	J	Cl ₂
K	NH ₃	L	ClO ₂	M	O ₃	O	LEL	P	PID
Q	IR								
Correction Factor Codes for PID (if applicable)									
A	Acetaldehyde	B	Acetone	C	Ammonia	D	Benzene	E	Butadiene
F	Diesel	G	Ethanol	H	Ethylene	I	Gasoline	J	Hexane
K	Isobtyln	L	JP8	M	Kerosene	N	MEK	O	Naptha
P	Styrene	Q	Toluene	R	Turpentine	S	Vinyl_Cl	T	Xylene
U	Custom								
Correction Factor Codes for LEL									
A	Acetone	B	Benzene	C	Butane	D	Cyclohexane	E	Ethanol
F	Ethyl_Ace	G	Gasoline	H	Heptane	I	Hexane	J	Hydrogen
K	Isobutylene	L	Isopropanol	M	MEK	N	Methane	O	Methanol
P	Octane	Q	Pentane	R	Propane	S	Toluene	T	Turpentine
U	Custom								
LEL Unit Codes									
V	LEL in % by Vol CH ₄			L	LEL in % LEL				

Maintenance

To maintain the detector in good operating condition, perform the following basic maintenance as required.

- Calibrate, bump test, and inspect the detector at regular intervals.
- Maintain an operations log of all maintenance, calibrations, bump tests, and alarm events.
- Clean the exterior with a soft damp cloth. Do not use solvents, soaps, or polishes.
- Do not immerse the detector in liquids.

Replacing/Charging the Batteries

⚠ Warning

To avoid personal injury, adhere to the following:

- ⇒ **Replace the batteries immediately when the detector emits a low battery alarm.**

- ⇒ **Use only batteries that are recommended by BW Technologies to prevent personal injury and/or property damage.**

- ⇒ **Use only approved batteries, properly installed in the detector case. Refer to [Specifications](#) for approved batteries.**

- ⇒ **Charge batteries using only a recommended BW charger. Do not use any other charger. Failure to adhere to this precaution can lead to fire and/or explosion.**

- ⇒ **Both the rechargeable battery pack and the alkaline battery pack are hot-swappable, but the alkaline battery cells inside the pack can only be replaced in a non-hazardous location.**

Note

To preserve battery life, deactivate the detector when not in use.

To charge the rechargeable battery pack, refer to the *GasAlertMicro 5 Battery Charger User Manual*.

To replace the alkaline batteries, refer to Table 18, Figure 7, and the following procedures.

Table 18. Replacing the Batteries

Item	Description
1	Detector
2	Latch
3	Battery pack
4	Battery tray
5	Captive screws (2)
6	Alkaline batteries (3)
7	Battery shell

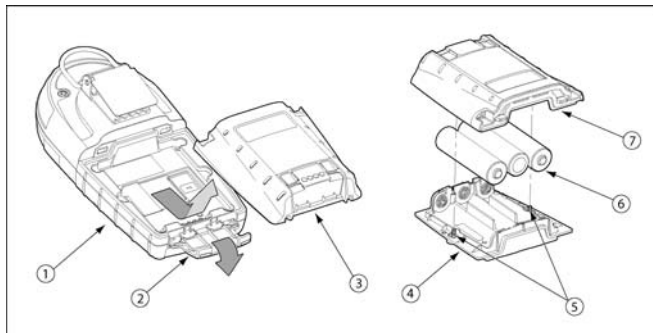

Figure 7. Replacing the Batteries

1. Open the latch on the bottom of the detector.
2. Remove the battery pack by lifting the bottom of the pack away from the detector.
3. Unscrew the two captive screws on the battery pack and open the pack.
4. Replace the three alkaline batteries and screw the battery pack back together.
5. Reinsert the battery pack and secure the latch.

Replacing a Sensor or Sensor Filter

⚠ Warning

To avoid personal injury, use only sensors specifically designed for the detector. Refer to [Replacement Parts and Accessories](#).

Each sensor has a high degree of resistance to common vapors and gases. To clear a sensor, move the detector to a clean environment and wait 10 to 30 minutes.

Do not expose a sensor to vapors of inorganic solvents such as paint fumes or organic solvents. Refer to [Troubleshooting](#) for reference to problems caused by a sensor that requires calibration or replacement.

To replace a sensor or sensor filter, refer to Figure 8, Table 19, and the following procedures.

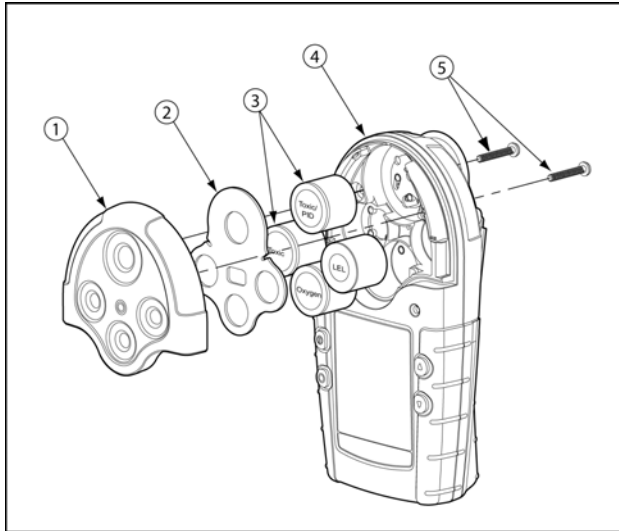

Figure 8. Replacing a Sensor or Sensor Filter

Note

Detectors that are configured for 1, 2, 3, or 4 gases may contain a dummy sensor in one of the four sensor locations.

Table 19. Replacing a Sensor or Sensor Filter

Item	Description
1	Sensor cover
2	Sensor filter
3	Sensors
4	Detector
5	Machine screws (2)

1. If required, deactivate the detector.
2. Remove the two machine screws on the rear shell and then remove the sensor cover or optional pump module.
3. Remove the sensor filter and/or the sensor(s). Gently rocking the sensor back and forth may help free a tightly held sensor.
4. Insert the new filter and/or sensor. Ensure the sensor posts are aligned correctly.
5. Re-assemble the detector.
6. If the sensor is changed (eg. SO₂ to an H₂S), the detector must be reconfigured. Refer to the [Sensors](#) in the [Tech Mode](#) option.
7. Calibrate the detector after changing any sensor(s). Refer to [Calibration and Setting Alarm Setpoints](#).

Photoionization Detector (PID)

Clean or Replace the Lamp

The PID lamp must be cleaned on a regular basis. Use only the cleaning kit that is supplied by BW Technologies.

To clean the PID lamp, refer to the illustrations and procedures that are provided with the *PID Lamp Cleaning Kit*. To order the kit, refer to [Replacement Parts and Accessories](#).

Note

To ensure proper maintenance and continued accurate readings from the sensor, use only the *PID Lamp Cleaning Kit* that is provided by BW Technologies.

Table 20. Parts of the PID sensor

Item	Description
1	Sensor cover
2	Electrode stack
3	Diffusion barrier
4	Lamp
5	PID sensor

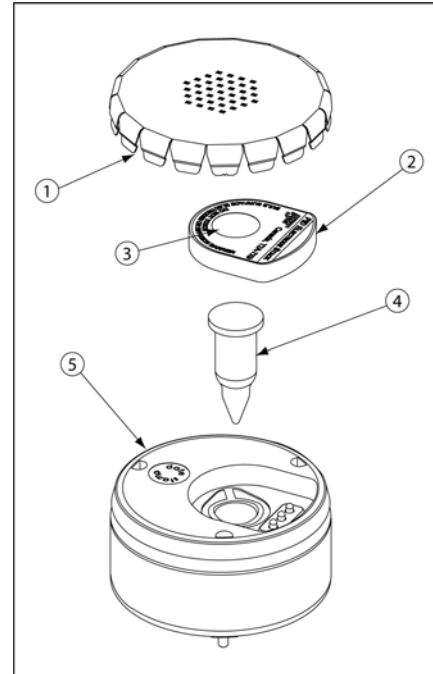

Figure 9. Parts of the PID

Replace the Lamp

Replace the lamp when it falls below the acceptable level. Possible indicators that the lamp requires replacement are as follows:

- The detector will not calibrate.
- The start-up self-test fails.
- The ppm levels are incorrect.

To replace the lamp, refer to the illustrations and procedures in the *PID Lamp Cleaning Kit*.

If required, contact [BW Technologies](http://www.bwtechnologies.com) for more information.

Replace the Electrode Stack

Replace the electrode stack when it is contaminated. To replace the electrode stack, refer to Table 20, Figure 9, and the following procedures.

1. Remove the sensor cover.
2. Remove the old electrode stack.
3. Insert the new electrode stack.

Note

Ensure your fingers do not make contact with the diffusion barrier or the electrodes on the underside of the stack.

4. Replace the sensor cover.

Troubleshooting

If the problem persists, contact [BW Technologies](#).

If a problem occurs, refer to the solutions provided in Table 21.

Table 21. Troubleshooting Tips

Problem	Possible Cause	Solution
The detector does activate.	No batteries Depleted batteries Damaged or defective detector	Refer to Replacing/Charging the Batteries . Refer to Replacing/Charging the Batteries . Contact BW Technologies .
The detector immediately enters alarm mode when activated.	Sensor needs to stabilize Low battery alarm Sensor alarm Pump alarm	Used sensor: wait 60 seconds New sensor: wait 5 minutes Refer to Replacing/Charging the Batteries . Refer to Replacing a Sensor or Sensor Filter . If the sampling hose is attached, determine if it is obstructed. If not, clean or replace the pump filter. If pump alarm persists, contact BW Technologies .
The activation self-test fails.	General fault	Ensure that the sensors and battery pack are installed correctly and then restart the detector. If fault persists, record the error message and contact BW Technologies .

Table 21. Troubleshooting Tips (cont.)



Problem	Possible Cause	Solution
 <p>MMC/SD card missing</p>	<p>The MMC/SD is not inserted</p>	<p>Insert the MMC/SD card. Refer to Inserting the MMC/SD Card.</p>
 <p>MMC/SD size not supported</p>	<p>The MMC/SD card that is inserted in the detector has a storage size that is not supported by the detector</p>	<p>Insert an Infineon MMC/SD card that is</p> <ul style="list-style-type: none"> • 32 MB only
 <p>MMC/SD communica- tion error</p>	<p>The detector has lost communication with the MMC/SD card</p>	<p>Attempt the following solutions:</p> <ul style="list-style-type: none"> • Retry communication • Insert a different Infineon MMC 32 MB • Clear MMC in windows and reinsert into the detector. • Contact BW Technologies.

Table 21. Troubleshooting Tips (cont.)

Problem	Possible Casue	Solution
The detector displays a clock error message using last recorded time.	General fault	Reactivate the detector. If the message does not display, reset the clock in user options. If the error message still displays, contact BW Technologies .
Detector does not display normal ambient gas reading after activation self-test.	Sensor not stabilized Detector requires calibration Target gas is present	Used sensor: wait 60 seconds New sensor: wait 5 minutes Refer to Calibration and Setting Alarm Setpoints . Detector is operating properly. Use caution in suspect areas.
Detector does not respond to pushbuttons.	Batteries are depleted Detector is performing operations that do not require user input.	Refer to Replacing/Charging the Batteries . Pushbutton function restored automatically when the operation ends.
Detector does not accurately measure gas.	Detector requires calibration Detector is colder/hotter than ambient gas Sensor filter is blocked	Refer to Calibration and Setting Alarm Setpoints . Allow the detector to acquire ambient temperature before using. Clean the sensor filter. Refer to Replacing a Sensor or Sensor Filter .

Table 21. Troubleshooting Tips (cont.)

Problem	Possible Cause	Solution
Detector does not enter alarm mode.	Alarm setpoint(s) are set incorrectly Alarm setpoint(s) set to zero Detector requires calibration	Reset alarm setpoints. Refer to Calibration and Setting Alarm Setpoints . Reset alarm setpoints. Refer to Calibration and Setting Alarm Setpoints . Calibrate the detector. Refer to Calibration and Setting Alarm Setpoints .
Detector intermittently enters alarm without any apparent reason.	Ambient gas levels are near alarm setpoint or the sensor is exposed to a puff of the target gas Alarms set incorrectly Missing or faulty sensor	Detector is operating normally. Use caution in suspect areas. Check MAX gas exposure reading. Reset alarm setpoints. Refer to Calibration and Setting Alarm Setpoints . Refer to Replacing a Sensor or Sensor Filter .
Detector automatically deactivates.	Automatic shutdown activated because of weak batteries	Refer to Replacing/Charging the Batteries .
Clock icon is flashing.	The clock has failed There is communication failure	Contact BW Technologies . Contact BW Technologies .

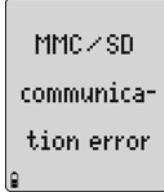
Replacement Parts and Accessories

⚠ Warning

To avoid personal injury and/or damage to the detector, use only the specified replacement parts.

To order parts or accessories listed in Table 22, contact [BW Technologies](#).

Table 22. Replacement Parts and Accessories

Model No.	Description	Qty
S4-W04	Combustible sensor	1
S4-W04-SF	Combustible sensor (with silicone filter)	1
SR-X10	O ₂ sensor	1
PS-RM04	CO sensor	1
PS-RH04S	H ₂ S sensor	1
SR-P04	PH ₃ sensor	1
PS-RS04	SO ₂ sensor	1
PS-RC10	Cl ₂ sensor	1
SR-A04	NH ₃ sensor	1
PS-RD04	NO ₂ sensor	1
PS-RZ10	HCN sensor	1
SR-V04	ClO ₂ sensor	1

Model No.	Description	Qty
SR-G04	O ₃ sensor	1
D4-RHM04	TwinTox CO/H ₂ S sensor	1
SR-Q07	PID sensor	1
RL-PID10.6	Lamp for PID sensor	1
M5PID-ES-1	Electrode stack for PID sensor	2
M5PID-CLN-K1	Cleaning kit for PID sensor lamp	1
M5-SS	Sensor filters (quad) kit of 2	2
CG-Q58-4	Quad calibration gas, CH ₄ -2.5%, O ₂ -18.0%, H ₂ S-25 ppm, CO-100 ppm, bal. N ₂ (58 l)	1
CG-Q34-4	Quad calibration gas, CH ₄ -2.5%, O ₂ -18.0%, H ₂ S-25 ppm, CO-100 ppm, bal. N ₂ (34 l)	1
CG-T34	Two gas calibration cylinder, 50% LEL (CH ₄ -2.5%) O ₂ -20.9%, bal. N ₂ (34 l)	1
CG2-S-25-58	Calibration gas, SO ₂ 25 ppm (58 l)	1
CG-BUMP-S25	SO ₂ bump test gas	1
CG-BUMP1	Bump alarm gas aerosol (CH ₄ -2.5%, O ₂ -10%, H ₂ S-40 ppm, CO-200 ppm)	1
REG-0.5	Regulator (0.5 l/min)	1

GasAlertMicro 5 and GasAlertMicro 5 PID*User Manual*

Model No.	Description	Qty
G0042-H25	Calibration gas, H ₂ S 25 ppm (58 l)	1
CG2-M-200-103	Calibration gas, CO 200 ppm (103 l)	1
CG2-S-25-58	Calibration gas, SO ₂ 25 ppm (58 l)	1
CG2-C-5-58	Calibration gas, Cl ₂ 5 ppm (58 l)	1
CG2-Z-10-58	Calibration gas, HCN 10 ppm (58 l)	1
CG2-D-10-58	Calibration gas, NO ₂ 10 ppm (58 l)	1
CG2-P-1-58	Calibration gas, PH ₃ 1 ppm (58 l)	1
CK-Q34-4	Quad calibration kit with regulator, quad gas cylinder (CG-Q34-4), hose and carrying case	1
CK-Q58-4	Quad calibration kit with regulator, quad gas cylinder (CG-Q58-4), hose and carrying case	1
CR-MMC-USB1	MMC USB reader (USB port) with software for user-downloadable datalogger	1
M5-MMC32	32 MB MultiMediaCard	1
M5-BAT01	Rechargeable battery pack	1

Model No.	Description	Qty
M5-BAT02	Alkaline battery pack	1
M5-CO1*	GasAlertMicro 5 battery charger	1
M5-CO1-BAT01*	GasAlertMicro 5 battery charger and battery pack kit	1
GA-V-CHRG4	Vehicle GasAlertMicro 5 battery charger	1
M5-PUMP	Motorized Pump Module Kit	1
GA-PROB1-1	Sample pump with 1 ft./0.3 m probe tubing	1
M5-TC-1	Calibration cap and hose	1
GA-AG-2	Alligator clip (stainless steel)	1
GA-CH-2	Chest harness	1
GA-ES-1	Extension strap	1
GA-ARM-1	Arm band	1
GA-HM5	Belt holster	1

**Add suffix (-UK) for United Kingdom mains plug, (-EU) for European mains plug, (-AU) for Australian mains plug.*

Specifications

Instrument dimensions: 14.5 x 7.4 x 3.8 cm
(5.7 x 2.9 x 1.5 in.)

Weight: 370 g (13.1 oz.)

Operating and storage conditions

Temperature:

VOC: -10°C to +40°C (-14°F to +104°F)
Other gases: -20°C to +50°C (-4°F to +122°F)

Humidity:

O₂: 0% to 99% relative humidity (non-condensing)
VOC: 0% to 95% relative humidity (non-condensing)
Combustibles: 5% to 95% relative humidity
(non-condensing)
Cl₂: 10% to 95% relative humidity (non-condensing)
HCN, ClO₂: 15% to 95% relative humidity (non-condensing)
Other gases: 15% to 90% relative humidity
(non-condensing)

Pressure:

95 to 110 kPa

Alarm setpoints: May vary by region and are user-settable.

Detection range:

O₂: 0 – 30.0% vol. (0.1% vol. increments)
CO: 0 – 999 ppm (1 ppm increments)
CO (TwinTox sensor): 0 – 500 ppm (1 ppm increments)
H₂S: 0 – 500 ppm (1 ppm increments)
H₂S (TwinTox sensor): 0 – 500 ppm (1 ppm increments)
Combustibles: 0 – 100% LEL (1% LEL increments) or
0 – 5.0% v/v methane
PH₃: 0 – 5.0 ppm (0.1 ppm increments)
SO₂: 0 – 150 ppm (1 ppm increments)

Cl₂: 0 – 50.0 ppm (0.1 ppm increments)
NH₃: 0 – 100 ppm (1 ppm increments)
NO₂: 0 – 99.9 ppm (0.1 ppm increments)
HCN: 0 – 30.0 ppm (0.1 ppm increments)
ClO₂: 0 – 1.00 ppm (0.01 ppm increments)
O₃: 0 – 1.00 ppm (0.01 ppm increments)
VOC: 0 – 1000 ppm (1.0 ppm increments)

Sensor type:

H₂S/CO: Twin plug-in electrochemical cell
Combustibles: Plug-in catalytic bead
VOC: Photoionization detector (PID)
Other gases: Single plug-in electrochemical cell

O₂ measuring principle: Capillary controlled concentration sensor

Alarm conditions: TWA alarm, STEL alarm, low alarm, high alarm, multi-gas alarm, over range alarm, sensor alarm, pump alarm, MMC fail alarm, low battery alarm, confidence beep, automatic shutdown alarm

Audible alarm: 95 dB at 1 ft. (0.3 m) variable pulsed dual beepers

Visual alarm: Dual red light-emitting diodes (LED)

Display: Alphanumeric liquid crystal display (LCD)

Backlight: Automatically activates whenever there is insufficient light to view the LCD (if enabled) and during alarm conditions.

Self-test: Initiated upon activation

Calibration: Automatic zero and automatic span

Oxygen sensor: Automatic span upon activation (selectable)

GasAlertMicro 5 and GasAlertMicro 5 PID

User Manual

User field options: Confidence beep, latching low and high alarms, pass code protection, enable/disable safe display mode, enable/disable fast pump, combustible sensor measurement, sensor disable, TWA and STEL, language selection, enable/disable automatic oxygen calibration, set span concentration values, set STEL calculation period, set TWA method, gas measurement resolution, enable/disable automatic backlight, adjust clock calendar, and set logging rate (datalogger models only).

Datalogger units: Use only Infineon 32 MB MMCs

Battery operating time:

Toxic, O₂, and LEL sensors: 20 hours (three alkaline cells or one rechargeable battery pack)

Toxic, O₂, LEL, and PID sensors: 10 hours (three alkaline cells or one rechargeable battery pack)

Approved batteries: Approved batteries for product (standards IEC 60279-11, EN50020, UL913, C22.2 No. 157)

Alkaline:		Temperature Code
Duracell MN1500	-20°C ≤ Ta ≤ +50°C	T3C (139.8°C)
	-20°C ≤ Ta ≤ +40°C	T4 (129.8°C)
Energizer E91	-20°C ≤ Ta ≤ +50°C	T3B (163°C)
	-20°C ≤ Ta ≤ +40°C	T3C (153°C)

NiMH rechargeable:

M5-BAT01 -20°C ≤ Ta ≤ +50°C T4

Battery charger: GasAlertMicro 5 battery charger

First-time charge: 4 hours per battery pack

Normal charge: 3-4 hours per battery pack

Warranty: 2 years including sensors
(1 year for NH₃ sensor and PID lamp)

Approvals

Approved by CSA to both U.S. and Canadian Standards

Approved: Class I, Division 1, Group A, B, C, and D;
Class I, Zone 0, Group IIC

Standards: CAN/CSA C22.2 No. 157 and C22.2 152
ANSI/UL – 913 and ANSI/ISA – S12.13 Part 1

ATEX: CE 0539  II 1 G EEx ia IIC
KEMA 05ATEX 1096X

IECEx: Ex ia IIC

ABS Type Approved: VA-348169-X

This equipment has been tested and found to comply with the limits for a Class B digital device, pursuant to Part 15 of the FCC Rules and ICES-003 Canadian EMI requirements. These limits are designed to provide reasonable protection against harmful interference in a residential installation. This equipment generates, uses and can radiate radio frequency energy and, if not installed and used in accordance with the instructions, may cause harmful interference to radio communications. However, there is no guarantee that interference will not occur in a particular installation. If this equipment does cause harmful interference to radio or television reception, which can be determined by turning the equipment off and on, the user is encouraged to try to correct the interference by one of more of the following measures:

- Reorient or relocate the receiving antenna.
- Increase the separation between the equipment and receiver.
- Connect the equipment into an outlet on a circuit different from that to which the receiver is connected.
- Consult the dealer or an experienced radio/TV technician for help.

General Specifications for Datalogger Units

Media type: MultiMediaCard (MMC)

Size: 32 MB (Infineon MMC only)

Storage: 500,000 lines of data available; 4.4 months at 5 second intervals (based on a normal work week)

Memory type: Wrap-around memory ensures most recent data is always saved

Sample rate: One reading every 5 seconds (standard)

Data recorded: All sensor readings, all alarm conditions, calibrations, event flags, battery status, pump status, sensor status, confidence beep activation, and detector status along with the time and date for each reading and unit serial number

MMC/SD test: Automatically on activation

GasAlertMicro 5 and GasAlertMicro 5 PID with User Downloadable Datalogger

Operation: Requires no user intervention (automatic)

Indicators: Icon advises datalogger is operating normally, MMC/SD missing/malfunction advise

Compatible with: Desktop PC computer or laptop

Operating system: Windows 95 or higher; Macintosh OS 8.6 or higher

Download via: MMC/SD card reader.

Software required: Spreadsheet or database compatible with comma-separated-value (CSV) text files (Excel, Access, Quattro, etc.)

Card alarm: Card fail or missing

Support:

Fleet Manager: Fleet Manager is an Access software add-in that enhances the abilities of Microsoft® Access when handling GasAlertMicro 5 user downloadable datalogger data files.



Appendix A PID Correction Factor (CF) Library

Table 23. PID Corrections Factor (CF) Library

Gas #	Gas Type	LCD Gas Type Abbreviation	Correction Factor Value (CF values subject to change)
1	No PID correction factor	N/A	N/A
2	Acetaldehyde	Acetdhd	d'4.6'
3	Acetone	Acetone	d'1.2'
4	Ammonia	Ammonia	d'10.6'
5	Benzene	Benzene	d'0.5'
6	Butadiene	Butadien	d'0.9'
7	Diesel	Diesel	d'0.9'
8	Ethanol	Ethanol	d'13.3'
9	Ethylene	Ethylene	d'9.1'
10	Gasoline	Gasoline	d'0.7'
11	Hexane	Hexane	d'4.6'
12	Isobtyln	Isobtyln	d'1.0'
13	JP8	JP-8	d'0.5'
14	Kerosene	Kerosene	d'1.1'
15	MEK	MEK	d'0.9'

Table 23. PID Correction Factors (CF) Library (cont.)

Gas #	Gas Type	LCD Gas Type Abbreviation	Correction Factor Value (CF values subject to change)
16	Naptha	Naptha	d'1.0'
17	Styrene	Styrene	d'0.5'
18	Toluene	Toluene	d'0.5'
19	Turpentine	Turpentine	d'0.5'
20	Vinyl Chloride	Vinyl Chloride	d'2.2'
21	Xylene	Xylene	d'0.5'
22	Custom	Custom	0.1 to 15.0



D5615/1 (English)

iERP: 119085

© 2006 BW Technologies. All rights reserved. Printed in Canada.

All product names are trademarks of their respective companies.

