

Installation

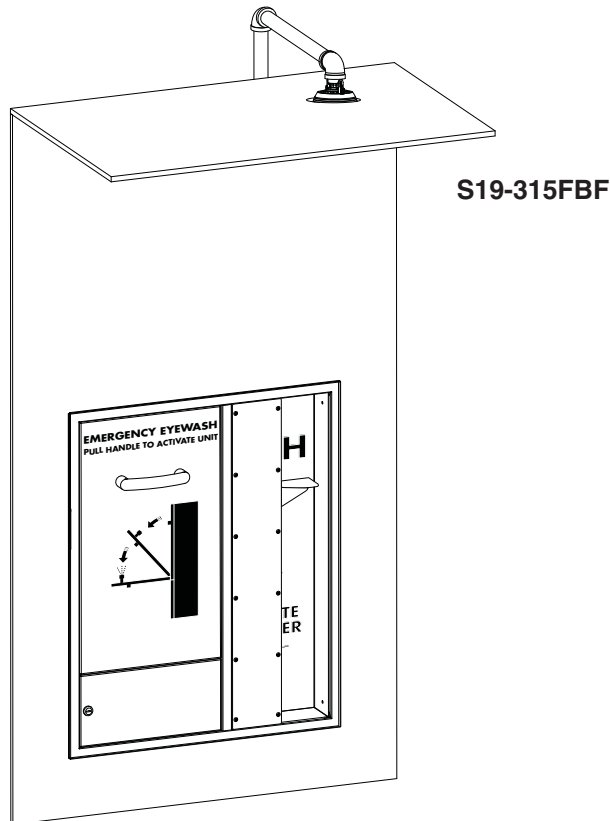
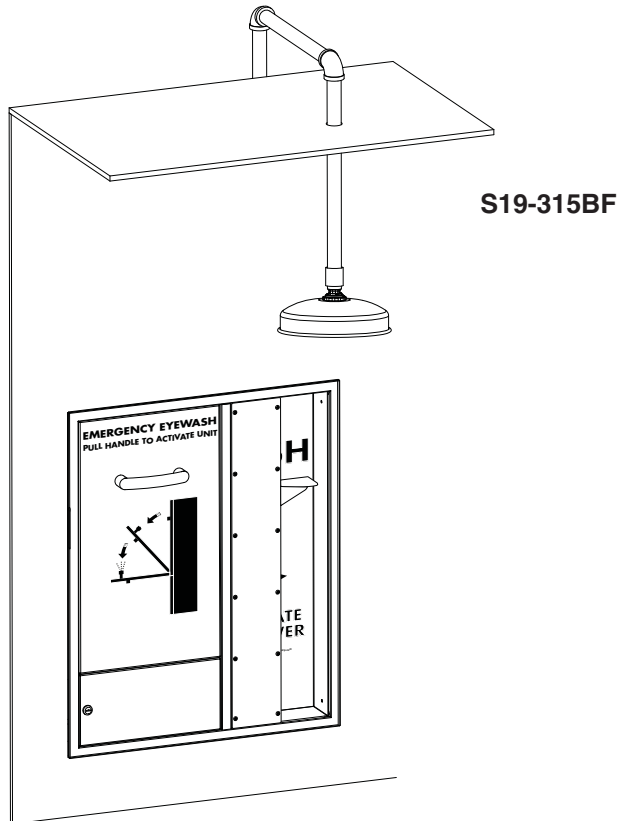

S19-315BF

S19-315FBF

S19-315PBF

S19-315FPBF

**Barrier Free Recess-Mounted
Drench Shower with Barrier Free
Cabinet-Concealed Swing-Down
Eyewash**

Table of Contents

Pre-Installation Information	2
Dimensions	3
Rough-Ins	4
Installation Instructions	5-6
Drench Shower Components and Parts List	7
Eyewash Components	8-9
Eyewash Parts List	10

⚠ IMPORTANT ⚠

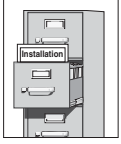

Read this installation manual completely to ensure proper installation, then file it with the owner or maintenance department. Compliance and conformity to drain requirements and other local codes and ordinances is the responsibility of the installer.



Separate parts from packaging and make sure all parts are accounted for before discarding any packaging material. If any parts are missing, do not begin installation until you obtain the missing parts.



Flush the water supply lines before beginning installation and after installation is complete. Test the unit for leaks and adequate water flow. Main water supply to the eyewash should be "ON" at all times. Provisions shall be made to prevent unauthorized shutoff.



The ANSI Z358.1 standard requires an uninterrupted supply of flushing fluid at a minimum 30 PSI (0.21 MPa) flowing pressure. Flushing fluid should be tepid per ANSI Z358.1.



The inspection and testing results of this equipment should be recorded weekly to verify proper operation. This equipment should be inspected annually to ensure compliance with ANSI Z358.1.



Workers who may come in contact with potentially hazardous materials should be trained regarding the placement and proper operation of emergency equipment per ANSI Z358.1.



For questions regarding the operation or installation of this product, visit www.bradleycorp.com or call 1-800-BRADLEY.

Product warranties and parts information may also be found under "Products" on our web site at www.bradleycorp.com.

Eyewash Cabinet Dimensions

Side View

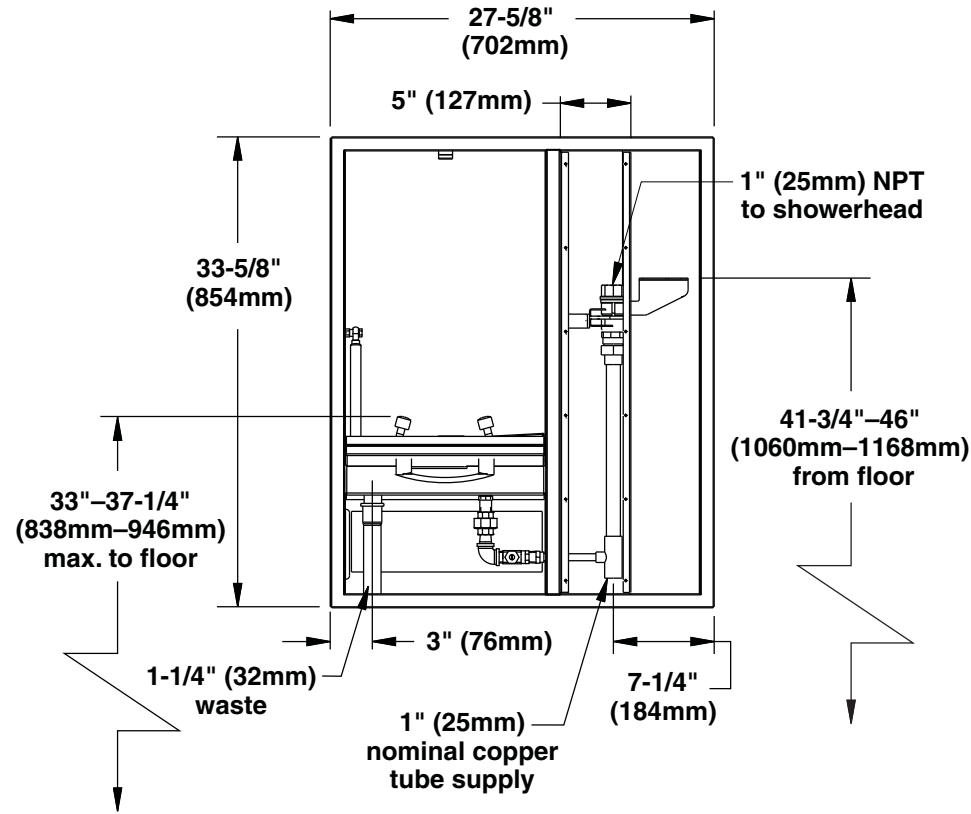

Front View

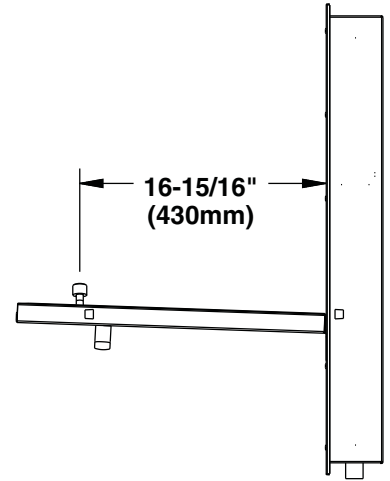

Bottom View

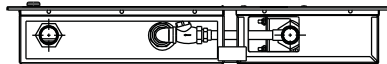

1 Rough-ins

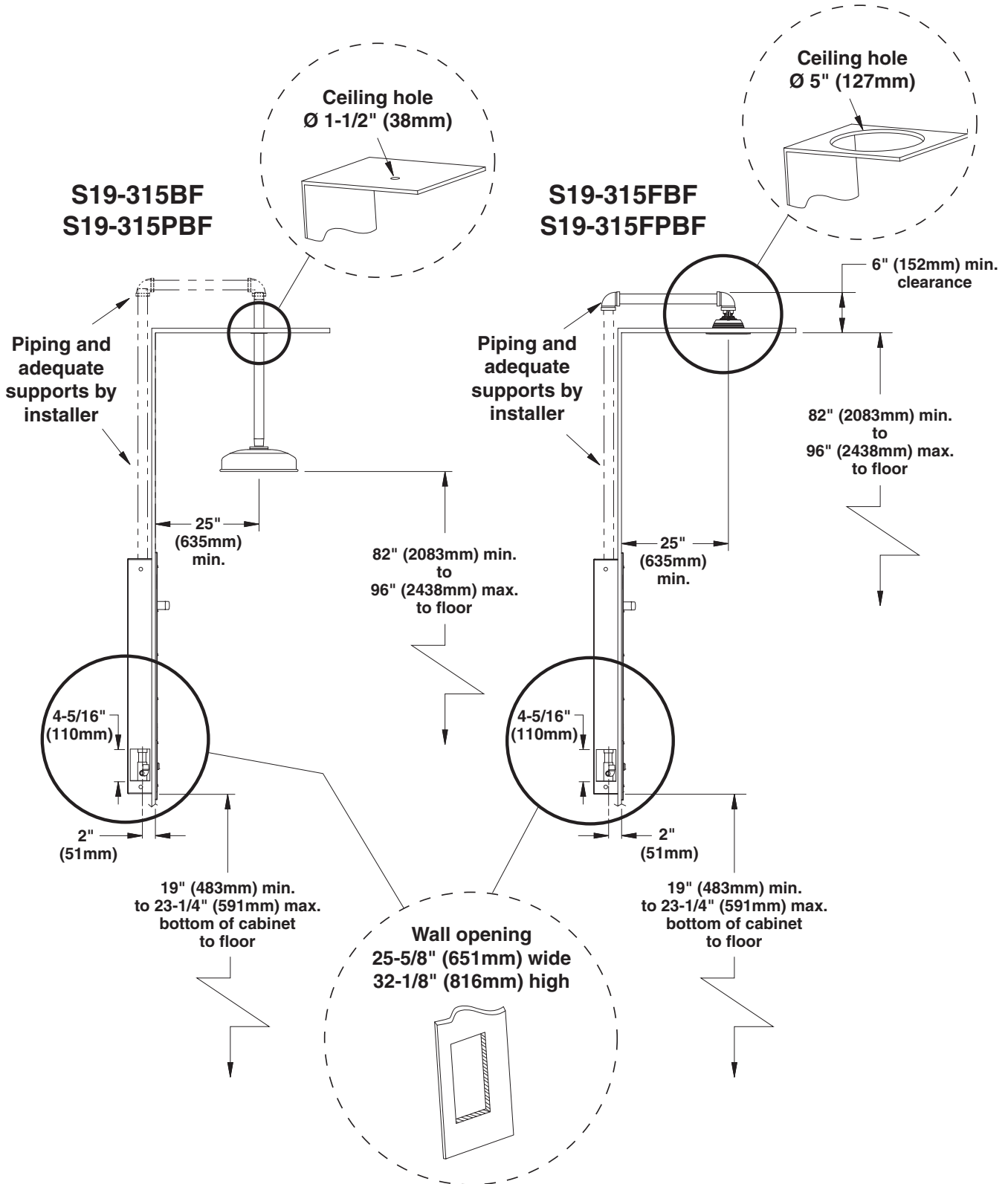

2 Installation

Piping and adequate supports by installer

S19-315BF
S19-315PBF

Piping and adequate supports by installer

S19-315FBF
S19-315FPBF

Supplied by installer

NOTE: Use teflon tape only.

NOTE: Use teflon tape only.

Secure cabinet to wall, four places.

3 Connect Water Supply



Mount safety sign to wall.

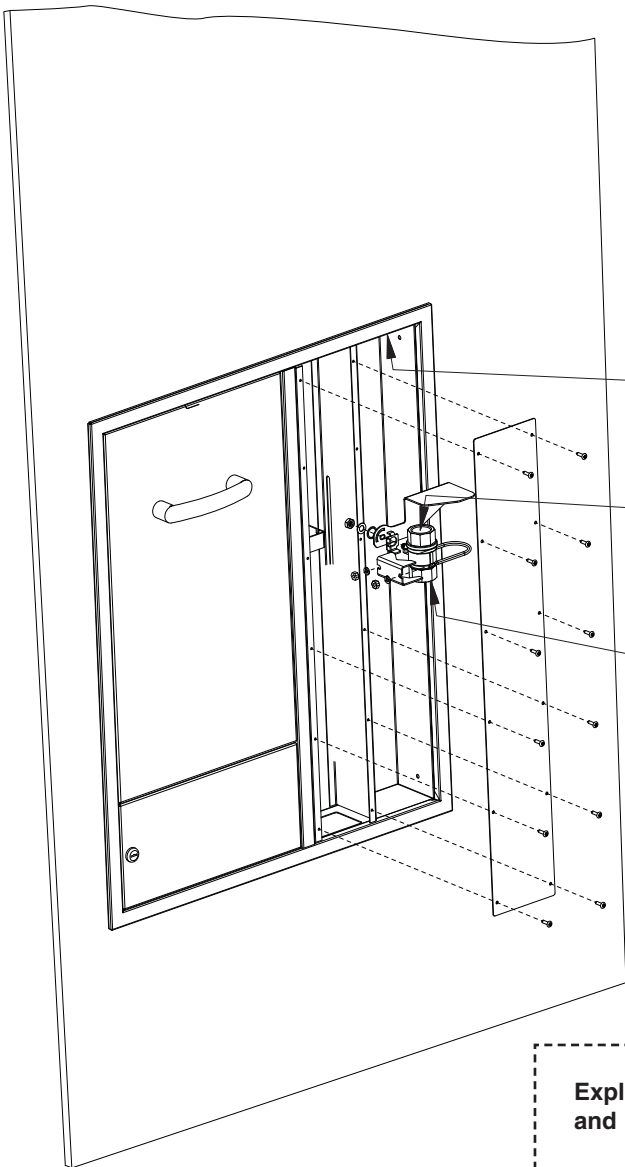

To showerhead

Connect 1" NPT supply piping

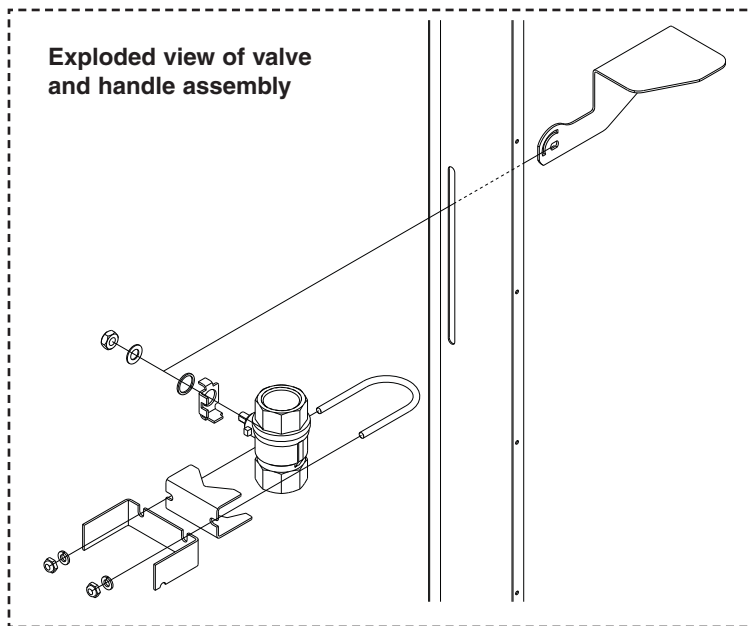

Exploded view of valve and handle assembly

Assembly of Components for Eyewash (parts list on page 10)

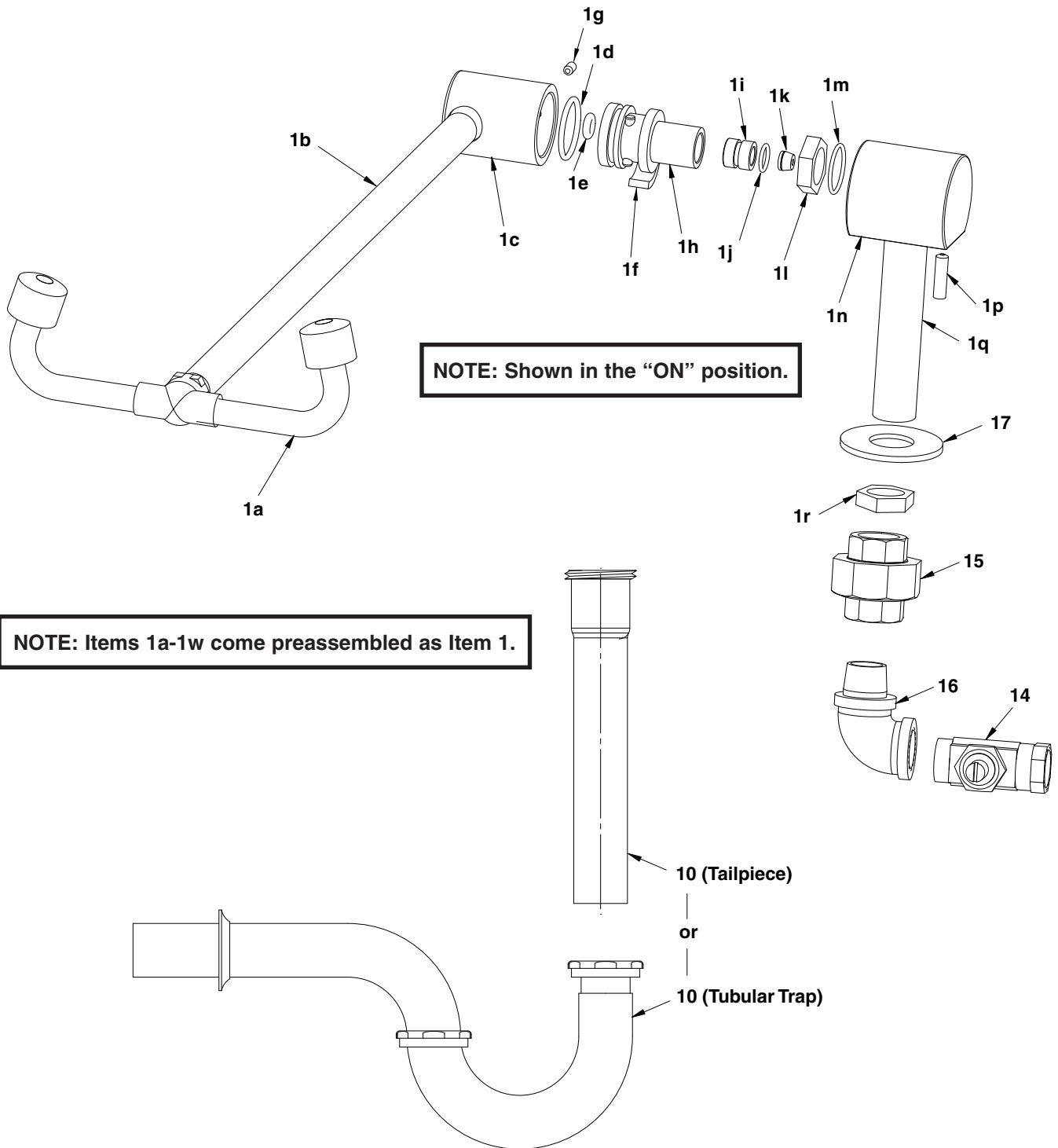

Assembly of Components for Eyewash *continued . . .*

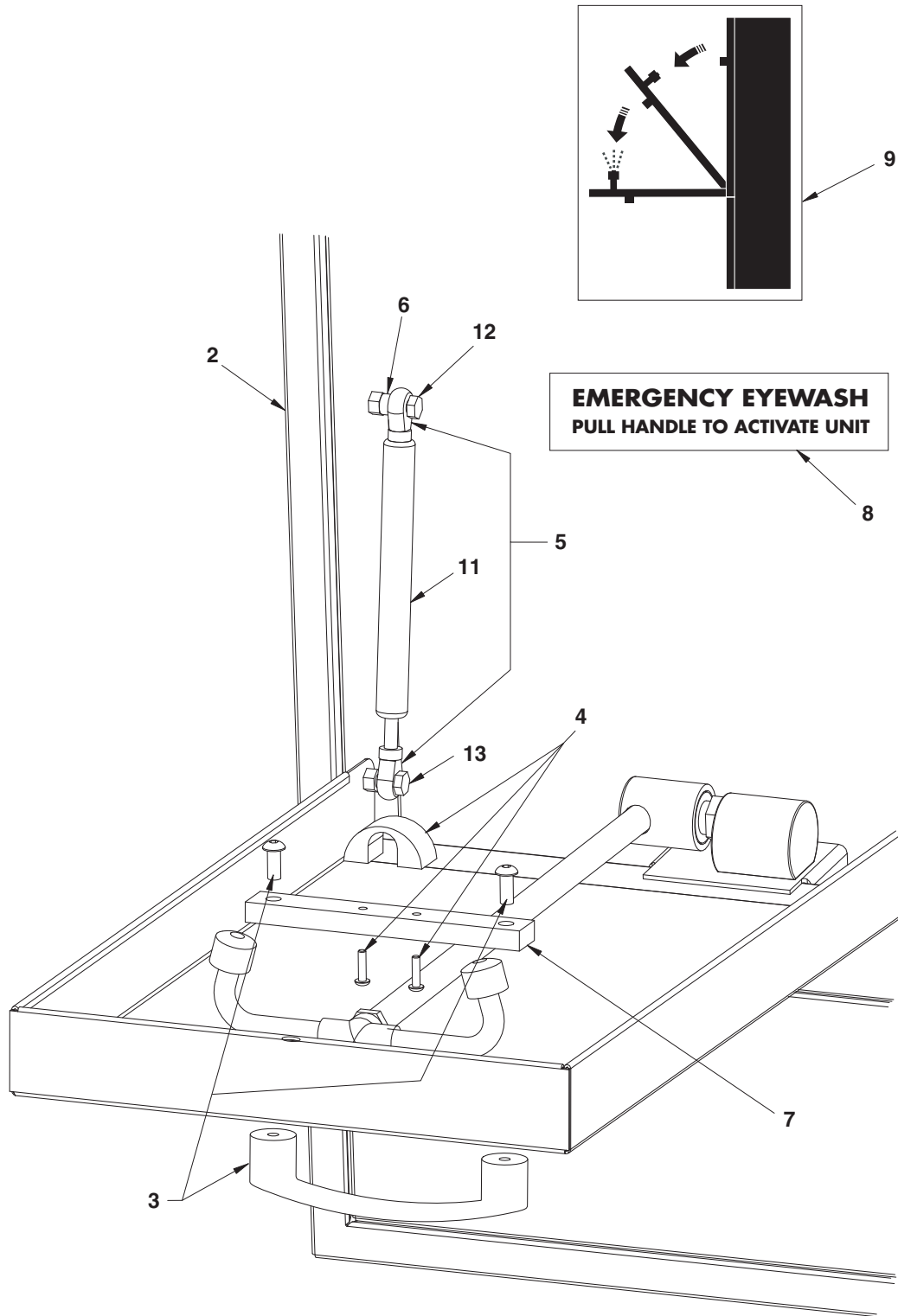

Parts List for Eyewash

Item	Part No.	Qty	Description	Item	Part No.	Qty	Description
1	S39-679	1	Eyewash Assembly	2	S39-691	1	Cabinet Assembly
1a	S05-092	1	Eyewash Yoke Assembly	3	S45-2196	1	Handle/Hardware Kit
1b	113-1125	1	Pipe - Plated	4	S45-2197	1	Swing-Down Stop Kit
1c	118-288	1	Valve Body - Plated	5	269-1836	2	Rod End
1d	125-120	1	O-Ring	6	182-118	1	Spacer
1e	125-135	1	O-Ring	7	140-949	1	Bracket, Swing-Down
1f	192-016	1	Insert, Direction - Plated	8	204-602	1	Decal, Pull Down Eyewash
1g	160-413	1	Screw, Set	9	204-603	1	Decal, Concealed Eyewash
1h	S39-598	1	Actuator Sub-Assembly - Valve	10	269-1830	1	Tailpiece
1i	132-047	1	Insert, Flow Control		<i>or</i>		
1j	125-001CS	1	O-Ring		269-142	1	Tubular Trap, 1-1/4"
1k	125-032	1	Flow Control	11	269-1835	1	Gas Spring
1l	110-115A	1	Hex Nut - Plated	12	160-264	1	Bolt, 5/16"-18 x 1"
1m	125-001DA	1	O-Ring	13	160-458	1	Bolt, 5/16"-18 x 3/4"
1n	131-082	1	Base	14	S27-102	1	Stop Valve
1p	160-428	1	Screw, Set	15	169-348	1	Union
1q	113-1058	1	Shank	16	169-639	1	1/2" Elbow, 90°
1r	110-115	1	Hex Nut	17	142-002CB	1	Washer