

# Installation

## S19-671H

5-Gallon Tank with Eyewash and  
Heater Jacket

## S19-671HR

Heater Jacket Retrofit for 5-Gallon  
Tank

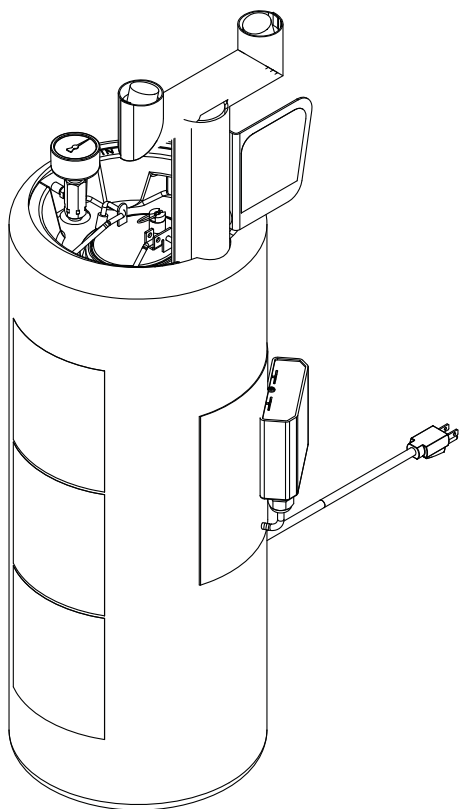

### Table of Contents

Pre-Installation Information . . . . .	2
S19-671H Installation . . . . .	3
S19-671HR Installation . . . . .	4
Maintenance and Troubleshooting . . . . .	5
Assembly of Components . . . . .	6
Parts List . . . . .	6

 **WARNING** 

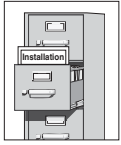

Read this installation manual completely to ensure proper installation, then file it with the owner or maintenance department. Compliance and conformity to drain requirements and other local codes and ordinances is the responsibility of the installer.



Separate parts from packaging and make sure all parts are accounted for before discarding any packaging material. If any parts are missing, do not begin installation until you obtain the missing parts.



Flush the water supply lines before beginning installation and after installation is complete. Test the unit for leaks and adequate water flow.

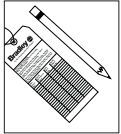

The inspection and testing results of this equipment should be recorded weekly to verify proper operation. This equipment should be inspected annually to ensure compliance with ANSI Z358.1.



Workers who may come in contact with potentially hazardous materials should be trained regarding the placement and proper operation of emergency equipment per ANSI Z358.1.



For questions regarding the operation or installation of this product, visit [www.bradleycorp.com](http://www.bradleycorp.com) or call 800.BRADLEY (800.272.3539).

Product warranties and service parts information may also be found under "Products" on our web site at [www.bradleycorp.com](http://www.bradleycorp.com).



Disconnect before servicing. Inspect cord for fraying. Make sure there is no visible damage to the yoke's electrical system.

**Supplies Required:**

- Pipe sealant
- Clean (free of oil and contaminants) air pressure equipment or supply capable of up to 100 psi.
- Sign-mounting hardware

## Installation S19-671H

### Step 1: Install Eyewash

1. Remove the plastic dust plug from the bottom of the yoke assembly and discard. Attach the eyewash yoke assembly to the tank (see page 6). Max. torque 150 In-Lbs.

**⚠ IMPORTANT:** When connecting the pressure gauge to the tank inlet, hold the adapter (item 3) with a wrench to prevent stripping. Failure to do so may damage the seal and cause leakage. Max. torque 150 in-lbs.

2. Connect the pressure gauge to the adapter on the pressure side of the tank with pipe sealant (by installer) (see page 6).

### Step 2: Install Heater Jacket

1. Secure the pipe insulation and jacket to the eyewash yoke assembly.
2. Wrap the belt around the tank four inches from the bottom of the tank.

*NOTE: For ease of assembly, line up the power cord from the heater pad directly below the eyewash yoke assembly. Make sure the heater belt and tank are clean and free of debris, then secure the belt to the tank.*

3. Connect the heat trace cable to the junction box.
4. Slide the jacket up the outside of the tank.

*NOTE: For ease of assembly, line up the pocket on the jacket, just to the side of the eyewash yoke, away from the retaining spring on the heater pad.*

5. Place the junction box in the pocket on the inside of the jacket. Route the power cord out of the bottom of the hook-and-loop slot in the jacket.
6. Pull the drawstring tight at the top of the jacket.

### Step 3: Fill tank and pressurize

1. If the tank is pressurized, relieve the tank pressure by pulling up on the relief tank tab in the center of the cover until the pressure gauge reads "0."

**⚠ IMPORTANT:** DO NOT open the cover until the pressure gauge reads "0."

2. Open the tank by pulling up on the wire handle located on top of the Quicklock cover. Push down, rotate and remove. Fill the container with 4 gallons of potable water. Replace the cover.
3. After filling the tank with water and before pressurizing the unit, cycle the valve from the closed to open and back to closed. Pressurize the tank to 90 PSI by applying air pressure to the tank valve located beneath the pressure gauge.

*NOTE: Relief valve is designed to automatically vent at 100-130 psi to prevent the tank from overpressurizing.*

### Step 4: Flush tank

1. Discharge the water through the eyewash for at least five minutes to flush the system.
2. Refill the tank and pressurize as explained in Step 3 outlined above.

*NOTE: Let unit stand for one hour. If there is a noticeable pressure drop, repressurize and let stand for one hour. If problems persist, consult the Troubleshooting guide found on page 5.*

*NOTE: This unit will provide at least 7 minutes of cleansing action. Take the injured person immediately to a normal emergency station for additional cleansing and treatment.*

3. Inspect the electrical components for any visible damage or fraying. Plug the heater jacket's electrical cord into an appropriate electrical outlet in accordance with state and local codes.

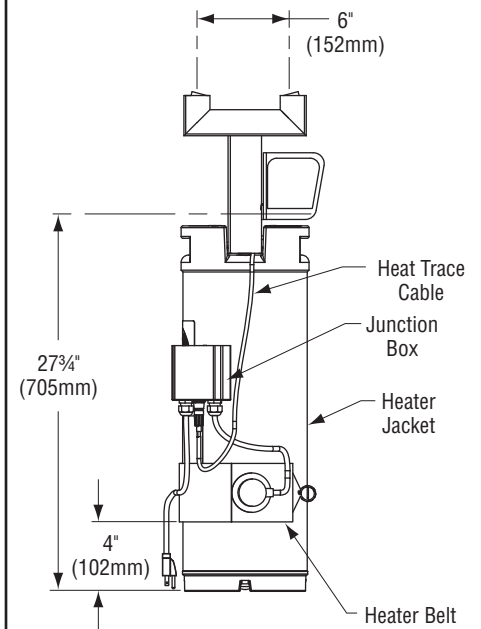
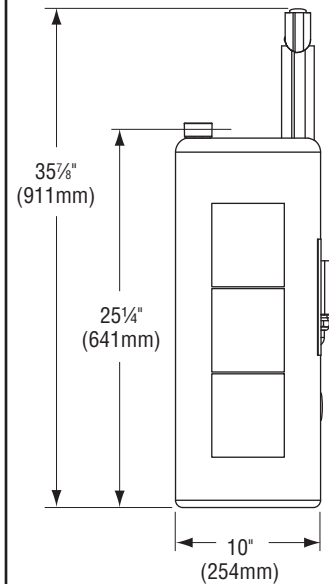

## Installation S19-671HR

### Step 1: Disassemble Eyewash

1. If the tank is pressurized, relieve the tank pressure by pulling up on the relief tank tab in the center of the cover until the pressure gauge reads "0."

**⚠ IMPORTANT: DO NOT open the cover or remove the eyewash yoke assembly until the pressure gauge reads "0."**

2. Empty the tank of any water.
3. Disconnect and remove the old eyewash yoke (and old heater belt and jacket, if previously installed). Inspect the tank fitting to ensure it is clean and undamaged.

### Step 2: Install Eyewash

1. Remove the plastic dust plug from the bottom of the yoke assembly and discard. Attach the eyewash yoke assembly to the tank (see page 6).

**⚠ IMPORTANT: When connecting the eyewash to the tank outlet, the max. torque must not exceed 150 in-lbs.**

### Step 3: Install Heater Jacket

1. Secure the pipe insulation and jacket to the eyewash yoke assembly.
2. Wrap the belt around the tank four inches from the bottom of the tank.

*NOTE: For ease of assembly, line up the power cord from the heater pad directly below the eyewash yoke assembly. Make sure the heater belt and tank are clean and free of debris, then secure the belt to the tank.*

3. Connect the heat trace cable to the junction box.
4. Slide the jacket up the outside of the tank.

*NOTE: For ease of assembly, line up the pocket on the jacket, just to the side of the eyewash yoke, away from the retaining spring on the heater pad.*

5. Place the junction box in the pocket on the inside of the jacket. Route the power cord out of the bottom of the hook-and-loop slot in the jacket.
6. Pull the drawstring tight at the top of the jacket.

### Step 4: Fill tank and pressurize

**⚠ IMPORTANT: DO NOT open the cover until the pressure gauge reads "0."**

1. Open the tank by pulling up on the wire handle located on top of the Quicklock cover. Push down, rotate and remove. Fill the container with 4 gallons of potable water. Replace the cover.
3. After filling the tank with water and before pressurizing the unit, cycle the valve from the closed to open and back to closed. Pressurize the tank to 90 PSI by applying air pressure to the tank valve located beneath the pressure gauge.

*NOTE: Relief valve is designed to automatically vent at 100-130 psi to prevent the tank from overpressurizing.*

### Step 5: Flush tank

1. Discharge the water through the eyewash for at least five minutes to flush the system.
2. Refill the tank and pressurize as explained in Step 4 outlined above.

*NOTE: Let unit stand for one hour. If there is a noticeable pressure drop, repressurize and let stand for one hour. If problems persist, consult the Troubleshooting guide found on page 5.*

*NOTE: This unit will provide at least 7 minutes of cleansing action. Take the injured person immediately to a normal emergency station for additional cleansing and treatment.*

3. Inspect the electrical components for any visible damage or fraying. Plug the heater jacket's electrical cord into an appropriate electrical outlet in accordance with state and local codes.

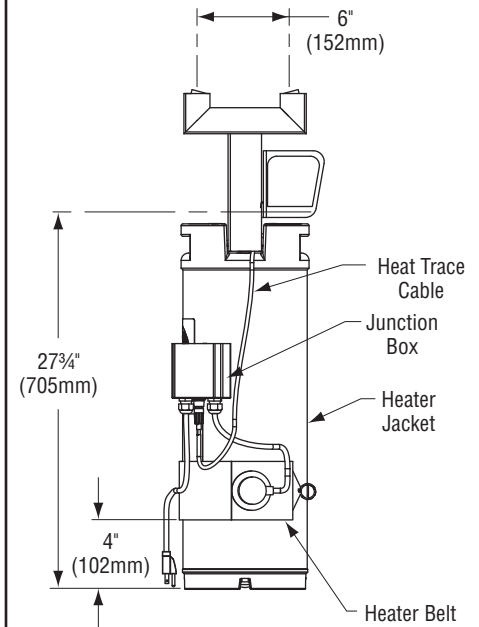
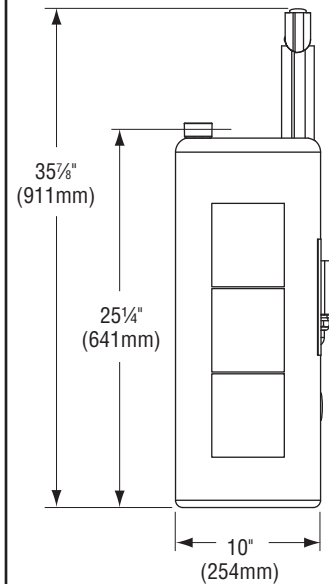

## Maintenance

**⚠ WARNING: Water preservatives protect potable water from bacteria, fungi and algae growth for up to 120 days. If a water preservative is not used with this eyewash, it is recommended that the tank be cleaned weekly or as often as needed. Infection, loss of vision or other serious injury may result from misuse of this eyewash. DO NOT use expired, cloudy, colored or contaminated solution. DO NOT open preservative bottle if safety seal is broken. DO NOT save unused solution.**

### Step 1: Inspect eyewash unit

1. Visually inspect the pressure gauge weekly to ensure the unit is maintaining the proper pressure. If the unit is not working properly, remove it from the hazard area immediately and refer to the troubleshooting instructions. For further assistance, contact the Bradley Corporation.

### Step 2: Clean eyewash unit

#### When using potable water *only*:

1. Empty the tank any time from once per week to once per month, depending on the quality of your water supply. The manufacturer is not responsible for variations in the water supply.
2. Clean the inside of the tank using warm water and mild soap. Rinse the tank thoroughly with warm water.
3. Refill the eyewash tank following the procedure outlined in Step 3 found on page 3.

#### When using potable water and water preservative (recommended):

1. Empty the tank at least once every 120 days.
  2. Clean the inside of the tank using warm water and mild soap. Rinse the tank thoroughly with warm water.
  3. Refill the eyewash tank with potable water and the contents of an 8-ounce bottle of water preservative (refer to the procedure outlined in Step 3 found on page 3).
- To order potable water preservative, contact your Bradley representative or local distributor and ask for part number S19-865.

## Troubleshooting

1. If pressure relief valve relieves prior to the required pressure, do the following (when in the unpressurized condition):
  - Tighten the valve completely into the cap by turning the gray hex head portion of the pressure relief valve clockwise. Do not use a wrench.
  - Pull up on the relief valve ring and ensure that the ring is not preventing the valve from closing completely. Push on the center pin of the relief valve to ensure that it is completely closed. Repressurize tank to required pressure. This may have to be done several times to get the valve to seat completely.
2. If the pressurized tank loses pressure over time, check the connections with diluted liquid dish soap or children's bubbles to identify the leak location. Tighten the connection slightly and test again.

# Assembly of Components and Parts List

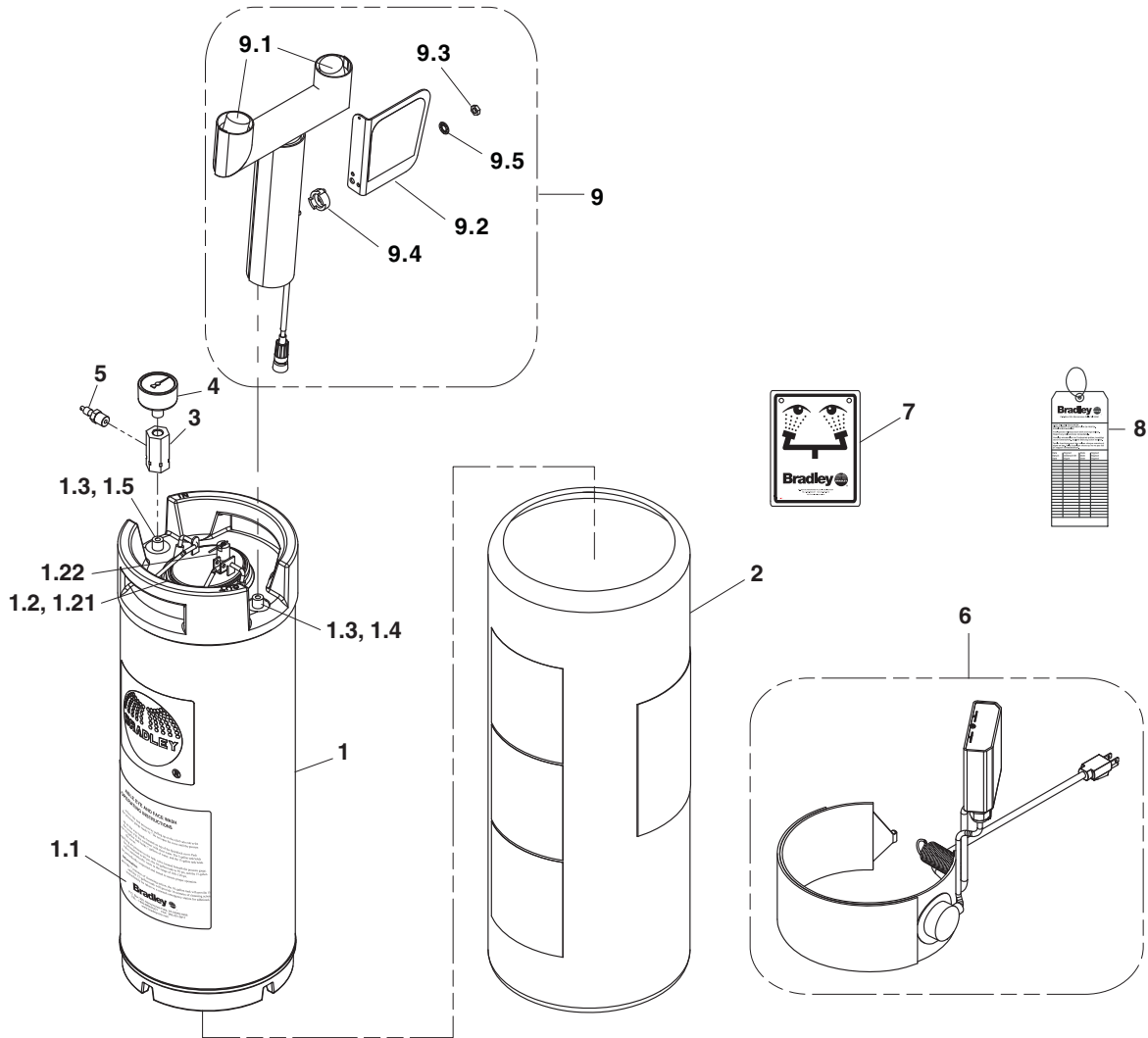

Item	Part No.	Qty.	Description	Item	Part No.	Qty.	Description
1	S39-784	1	Tank, 10-Gallon	4	169-786	1	Pressure Gauge
1.1	204-641	1	Operating Instr. Label, English	5	S27-320	1	Tank Valve Assembly
1.1	204-641FC	1	Operating Instr. Label, French	6	S83-163	1	Junction Box Assembly
1.1	204-641M	1	Operating Instr. Label, Spanish	7	114-051	1	Safety Sign
1.2	S44-024	1	Lid Assembly	8	204-421	1	Emergency Tag
1.21	269-1410	1	Gasket	9	S05-183H	1	Eyewash Assembly, Heated
1.22	269-1642	1	Relief Valve	9.1	107-371	2	Tethered Dust Cover
1.3	269-1411	2	O-Ring	9.2	S08-336	1	Handle/Label Assembly
1.4	269-1516	1	Draw Tube	9.3	110-215	1	Nut
1.5	269-1515	1	Level Indicator Tube	9.4	153-372R	1	Adapter
2	269-1971	1	Heater Jacket	9.5	142-002DA	1	Lockwasher
3	153-452	1	Adapter				

S45-2410 includes Items 1.21, 1.3